

# TRAILBOSS

Towbar Fitting Instructions  
To Suit **LEXUS RX450H GYL15R**  
Part Number **QTLX001L**  
Rating **1500/150 kg**

PLACE THESE INSTRUCTIONS IN THE VEHICLE'S GLOVEBOX AFTER INSTALLATION IS COMPLETED

## **WARNING:**

1. Do not, drill, cut, weld or otherwise modify the tow bar.
2. If you are using electric welding on a motor vehicle, **always** check that the vehicle is not equipped with electronic engine or instrument management equipment. Failure to do so could **destroy** any onboard computers. If in doubt, check with the vehicle's manufacturer.
3. The high tensile fasteners supplied with this product were used to achieve the specified rating. If replacement is required ensure that fasteners of the same rating & quality are used. Contact an authorised **Trailboss** dealer if further information is required.

## **General:**

1. Ensure all hardware items have been included refer to assembly diagram.
2. It is recommended that the instructions are read through and completely understood before making any attempt to fit this product.
3. Be wary of any changes to vehicle designs or other accessories that may conflict with the installation of this product.
4. Before drilling ensure that the area is clear of fuel, electrical & other components.
5. All holes drilled into the body panels shall have all burrs & swarf removed then coated with a suitable rust preventative paint.
6. For vehicles that require the bumper to be cut. Ensure cut out area is in correct position on the vehicle prior to cutting the bumper.
7. The high tensile fasteners supplied with this product were used to achieve the specified rating. If replacement is required ensure that fasteners of the same rating & quality are used. Contact an authorized **Trailboss** dealer if further information is required.
8. Ensure that all hardware is fastened to torque list below check fasteners on regular basis.
9. Tow bar load rating sticker provided with this product shall be conspicuously located on inside rear end of the driver's door. **(See diagram below).**
10. Trailboss recommends that you check your tow ball to ensure that it complies with the Australian standards **AS 4177.2**.
11. **PLEASE NOTE:** It is advised to remove your lug or tbm when not actually towing so as to produce a clear view of the vehicles registration plate if obscured, and to also provide maximum available departure angle

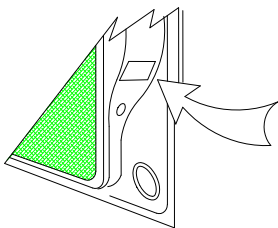

Place load rating sticker  
inside driver's door here

**FOR TRAILER TOWING PURPOSES ONLY**  
For towing capacity details please refer to vehicle owner's manual or to the manufacturer. Overloading can void your warranties.

### **RECOMMENDED ASSEMBLY TORQUE LISTING**

<u>Diameter</u>	<u>Grade 8.8 Bolt</u>
M6	9.5 Nm
M8	21.7 Nm
M10	43.4 Nm
M12	77.3Nm
M14	146 Nm
M16	189.8 Nm

## **Tow bar Maintenance and Care.**

Trailboss recommends that bolt torque's, as listed below, are routinely and regularly inspected and checked for correct tension. Replace any worn or defective parts.

We recommended to remove Tow Ball Mounts (TBM's, tongues or lugs) when not being used for any considerable length of time.

So as to avoid injury, when not towing it is suggested that the tongue, Pull Pin and R-clip are removed then stored in a safe, clean and dry place, away from excessive moisture.

# TRAILBOSS

Towbar Fitting Instructions  
 To Suit **LEXUS RX450H GYL15R**  
 Part Number **QTLX001L**  
 Rating **1500/150 kg**

PLACE THESE INSTRUCTIONS IN THE VEHICLE'S GLOVEBOX AFTER INSTALLATION IS COMPLETED  
 Hitch Pull Pins and spring "R" clips are regularly checked for proper installation. Replace any worn or defective parts.

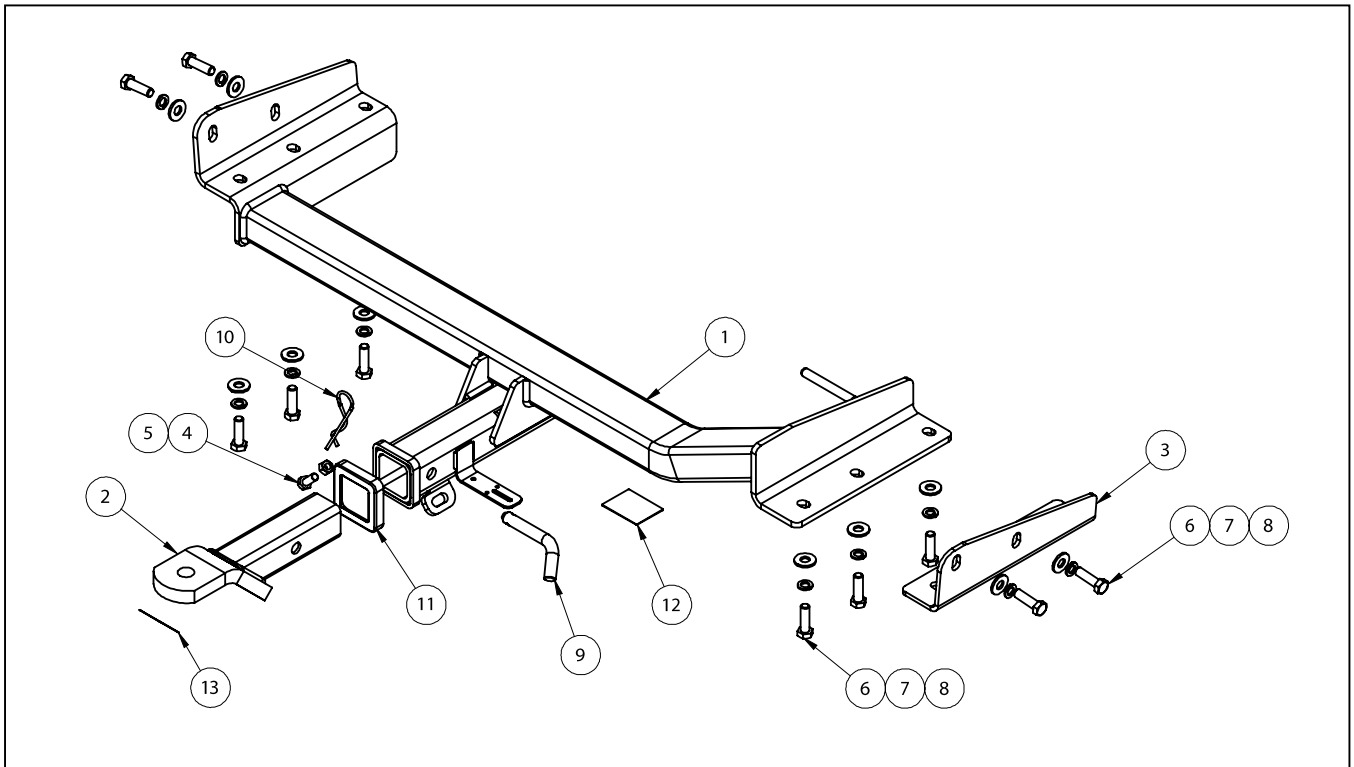

QTY.	DESCRIPTION	ITEM NO.
1	WELDED ASSEMBLY	1
1	T.B.MOUNT	2
1	SIDEARM DRIVER	3
1	BOLT M10x25x1.5P	4
1	HEX NUT M10x1.5P	5
10	BOLT M12x40x1.25P	6
10	M12 SPRING WASHER	7
10	M12 FLAT WASHER	8
1	PULL PIN	9
1	R CLIP	10
1	HITCH BOX COLLAR COVER	11
1	ACRYLIC COMPLIANCE PLATE LABEL	12

ADDITIONAL ITEMS

WIRING LOOM

FITTING INSTRUCTION      LR LABEL

# TRAILBOSS

Towbar Fitting Instructions  
To Suit **LEXUS RX450H GYL15R**  
Part Number **QTLX001L**  
Rating **1500/150 kg**

PLACE THESE INSTRUCTIONS IN THE VEHICLE'S GLOVEBOX AFTER INSTALLATION IS COMPLETED

## INSTRUCTION:

1. Remove the Mud Guard by removing 3x Bolts from either sides.
2. Remove the Bumper Cover by removing 4x Set Screws 2x Bolts from behind the Bumper Cover 3x Clips (1 from behind the Mud Guard on the Passenger Side); 2x Plastic Screws from the Driver Side of the body cover.
3. Remove the Driver Side Bumper Cover by removing 2x Set Screws; 2x Bolts; 2x Clips (1 from behind the Mud Guard on the Driver Side) for better access.
4. Remove the Shipping Hooks from Driver and Passenger Side and discard them. Remove the Plastic Plugs from underneath the Chassis Rail and also from the sides of the Rail.
5. Remove the Muffler from the Exhaust Hook Bracket and discard the Hook Bracket.
6. Mount the Sidearm Driver to the Chassis Rail , use 2xM12x40 Bolts with M12 Spring and Flat Washers; Mount Towbar to Passenger Side Chassis Rail, use 2xM12x40 Bolts with M12 Spring and Flat Washers ; Mount the Towbar Driver Side to Sidearm Driver, use 3 x M12x40 Bolts with M12 Spring and Flat Washers.
7. Torque all fasteners to specification on page 1.
8. Cut the side of Plastic under body tray 115mm wide all the way down to ribbing to allow clearance to Towbar. (Figure 1).
9. Using the Factory cut out section, cut 100mm wide and 270mm depth as shown in Figure 2. Neatly cut out, using a saw or similar device, remove all burrs.
10. Refit the Bumper cover in reverse order.

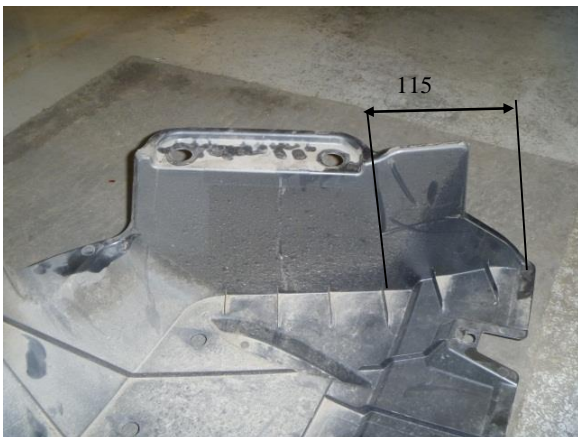

Figure 1

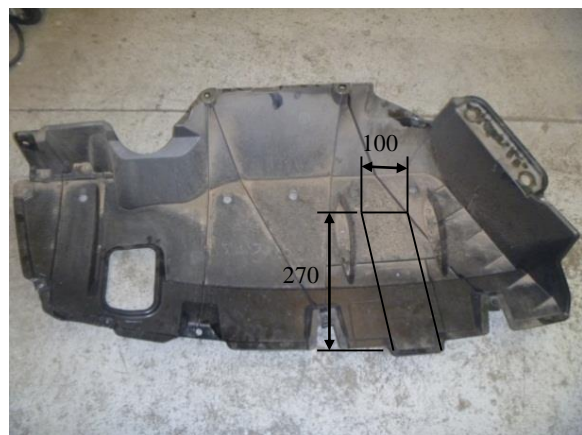

Figure 2



Wiring Loom Fitting Instructions  
To Suit Lexus AL10 RX305 / RX450H  
(December '08 Onwards)  
Part Number 100481-WL

## Wiring Loom Installation Instructions

Lexus AL10 RX350 / RX450H  
(December '08 Onwards)  
Part No: 100481-WL

ECU Required: 04826  
Tail Harness Length Required: 1800mm

Wiring Loom Installation Time: Approx 60 Mins



Wiring Loom Fitting Instructions  
To Suit Lexus AL10 RX305 / RX450H  
(December '08 Onwards)  
Part Number 100481-WL

1. In the luggage compartment, lift the floor cover upwards.
2. Remove the parcel shelf.
3. Remove the spare wheel cover.
4. Remove the LHS storage compartment by first removing the 4 clips .
5. Remove the LHS tool tray.
6. Remove the LHS floor cover carpet.

**Steps 7 & 8 are for RX450H vehicles only. For RX350 vehicles, please proceed to Step 9.**

7. Remove the rear battery cover.
8. Disconnect and remove the rear battery.
9. Remove the rear trim.
10. On the LHS of the luggage compartment, remove the LHS rear corner trim by first removing the clip.
11. Lift up the cover on the two cargo hooks and remove the two fasteners.
12. Remove the two rearmost clips from the LHS side lower trim.
13. Remove the LHS handle trim.
14. Remove the fasteners from the LHS parcel shelf guide.
15. Remove the fasteners cap and remove the fastener from the LHS upper trim.
16. Dislodge the LHS side trim and disconnect the two connectors.
17. Remove the three fasteners from the LHS floor bracket.
18. Remove the two fasteners from the subwoofer floor bracket.
19. Remove the three subwoofer fasteners.
20. Disconnect the subwoofer connector and remove the subwoofer from the vehicle.

Wiring Loom Fitting Instructions  
To Suit Lexus AL10 RX305 / RX450H  
(December '08 Onwards)  
Part Number 100481-WL

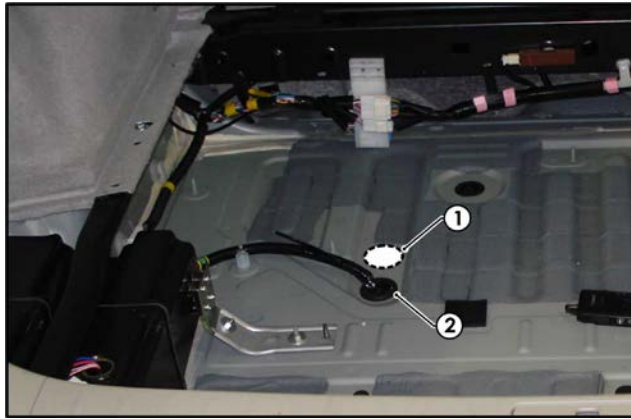

21. Drill a Ø30mm hole just behind the luggage compartment grommet.
22. File any rough or sharp edges and spray on rust inhibitor.
23. In the subwoofer cavity, locate the vehicle 12-way breakout connector (1).
24. Connect the trailer patch T-piece (2) to the breakout connector (1).

**Note: If breakout connector is occupied, disconnect and patch in between.**

25. Route the trailer patch (3) (P/No: 100481-WL) towards the rear of the luggage compartment.



26. Connect the trailer patch 12-way ECU connector to the ECU (04826).
27. Apply double sided tape to the ECU and adhere it to the flat surface of the LHS luggage compartment floor.
28. Ensure the ECU final mounting location will not restrict the fitment of the vehicle subwoofer.
29. Connect the trailer patch ground ring terminal to the existing vehicle earth point on the rear of the luggage compartment



Wiring Loom Fitting Instructions  
To Suit Lexus AL10 RX305 / RX450H  
(December '08 Onwards)  
Part Number 100481-WL

30. From the outside of the vehicle, mount the trailer socket to the towbar mounting bracket using M4 fasteners (not supplied).
31. Route the tail harness (tail length 1800mm) across the towbar towards the LHS of the vehicle and up through the previously drilled out hole.
32. Ensure the tail harness grommet is seated correctly and secure in place using a cable tie (not supplied).
33. Connect the tail harness 8-way connector to the trailer patch mating 8-way connector.
34. Test the trailer harness function using a Light Board or multi-meter.
35. Secure all harnesses using cables ties (not supplied).
36. Re-fit all removed parts and secure all fasteners, ensuring there are no squeaks or rattles.
37. Place the instructions in the glove box after fitment.



# FITTING INSTRUCTIONS

## Silent Anti-Rattle Hitch Pin (PR0001)

• These fitting instructions are supplied to ensure understanding of how the HITCH PIN should be fitted and used correctly.

• Once installed, we recommend **ALL** instructions are kept and placed in the vehicle glove box.

**NOTE: Routine maintenance and inspection of the towbar & HITCH PIN is required. Regularly inspect for wear and check the tightness of the Hitch Pin. Follow instructions below to retighten the nut when necessary.**

**\*Do not tow with your vehicle if the R CLIP or the HITCH PIN is loose or missing. Replacement parts are available from your Pro Series Distributor.**

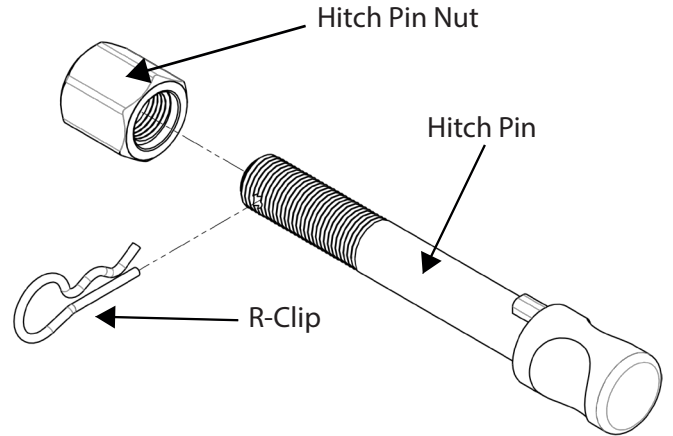

Fig 1. Silent Anti-Rattle Hitch Pin assembly

### STEP 1

Insert Trailer Ball Mount (TBM) into towbar HITCHBOX, aligning hole in TBM SHANK with hole in HITCHBOX (Fig 2).

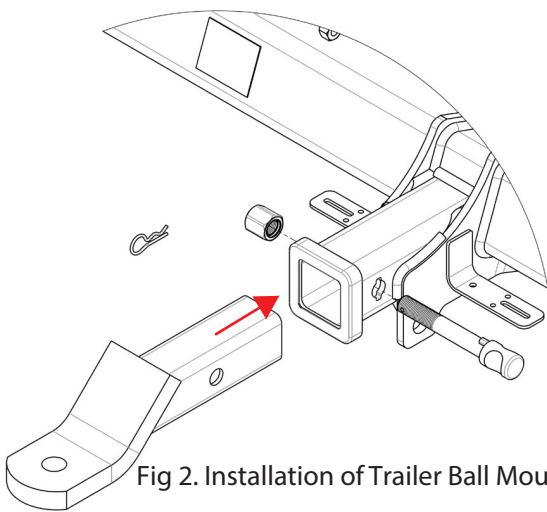

Fig 2. Installation of Trailer Ball Mount

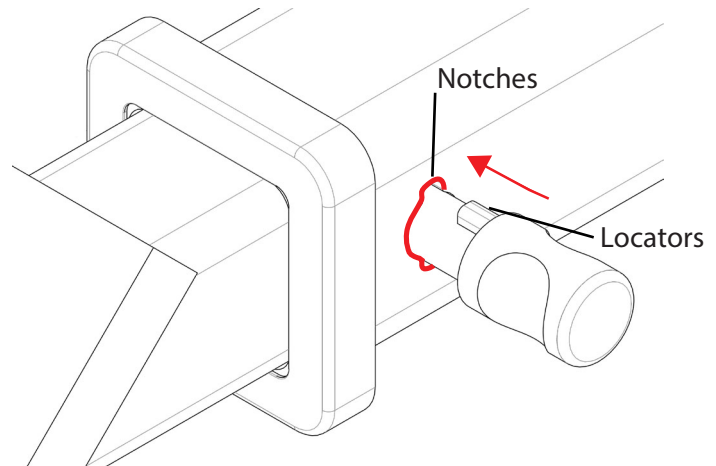

Fig 3. Silent Anti-Rattle Hitch Pin orientation

### STEP 2

Insert HITCH PIN through hole in HITCHBOX and hole in TBM SHANK; ensure the LOCATORS are inserted into the NOTCHES in the HITCHBOX (Fig. 3).

### STEP 3

Screw HITCH PIN NUT onto HITCH PIN ; tighten HITCH PIN NUT until finger tight, ensuring TBM is restrained from movement.

### STEP 4

Tighten HITCH PIN NUT by turning nut a further 1/8th of a turn in the clockwise direction using a 24mm spanner (Fig. 4).

### STEP 5

Install HITCH PIN R CLIP through the hole on the HITCH PIN (Fig. 1).

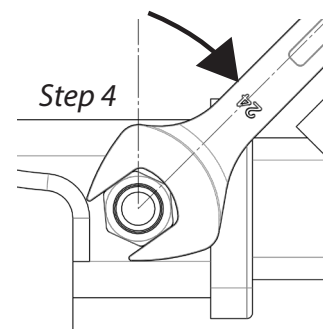

Fig 4. Tightening of Silent Anti-Rattle Hitch Pin Nut