



Towbar Fitting Instructions

To Suit TO SUIT MAZDA BT-50 & FORD RANGER TUB BODY 07-ON

NOTE: FITS BT-50 SDX VARIANTS WITH 8313 FIT KIT(ORDERED SEPERATELY)

Part Number QTMA433L

Rating 3000kg

NOTE: INORDER TO FIT RANGER XLT VARIANTS, THE STANDARD BAR & STEP ON THE VEHICLE NEEDS TO BE DISCARDED.

WARNING:

Do not, drill, cut, weld or otherwise modify the Towbar.

If you are using electric welding on a motor vehicle, **always** check that the vehicle is not equipped with electronic engine or instrument management equipment. Failure to do so could **destroy** any onboard **computers**. If in doubt, check with the vehicle's manufacturer.

1. Ensure all hardware items have been included.
2. Remove the factory fitted step by removing the bolts as shown in fig 1. Do not discard the bolts as they are used to fit the towbar to the vehicle.
3. Lower the spare wheel before putting up the towbar.
4. Lift towbar up into position so as holes in towbar align with tapped holes in end of chassis.
5. Fit the bolts for the 2nd rear most hole on both sides loosely.
6. Insert the bolt with wires provided, into the rearmost hole through the clearance hole along the side as shown in fig 1 & fit loosely using M12 whizz nuts provided.
7. Refit the bumper step by following the following steps:
NOTE: SDX VARIANTS NEED A FIT KIT (PART NO: 8313) TO REFIT THE BUMPER STEP, INSTRUCTIONS COME ALONG WITH THE KIT.
 - a) The arms of the bumper step have to be pushed outwards on both ends by 8mm to provide clearance for the side arms of the towbar.
 - b) On the passenger side of the bumper step, pack the arm of the step out buy fitting the packer provided as shown in fig 2.
 - c) On the driver side, make the slots on the bumper step side arm mounting plate bigger by 8mm, by redrilling a hole beside it or grinding it as shown in fig 3.
 - d) Remove the bracket on the Passenger side bumper step arm as shown in fig 4 & discard it.
 - e) Refit the bumper step on the outside of the side arms of the towbar using the same bolts removed in step 2.
8. Refit the spare wheel.
9. Tighten to torque listing.
10. Towbar rating sticker to be conspicuously located on inside rear end of the driver's door. (See diagram below)

Place load rating sticker inside driver's door here

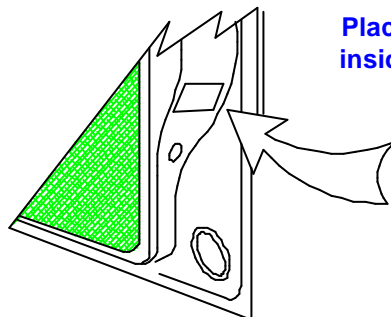

RECOMMENDED ASSEMBLY TORQUE LISTING
Diameter Grade 8.8 Bolt

M6	9.5 Nm
M8	21.7 Nm
M10	43.4 Nm
M12	77.3 Nm
M16	189.8 Nm

FOR TOWING PURPOSES ONLY
For towing capacity details please refer to vehicle owner's manual or to the manufacturer. Overloading can void your warranties.

Towbar Fitting Instructions

To Suit TO SUIT MAZDA BT-50 & FORD RANGER TUB BODY 07-ON

NOTE: FITS BT-50 SDX VARIANTS WITH 8313 FIT KIT(ORDERED SEPERATELY)

Part Number QTMA433L

Rating 3000kg

FIG 1: SHOWS SIDE ARM OF REAR BUMPER STEP FITTED TO CHASSIS

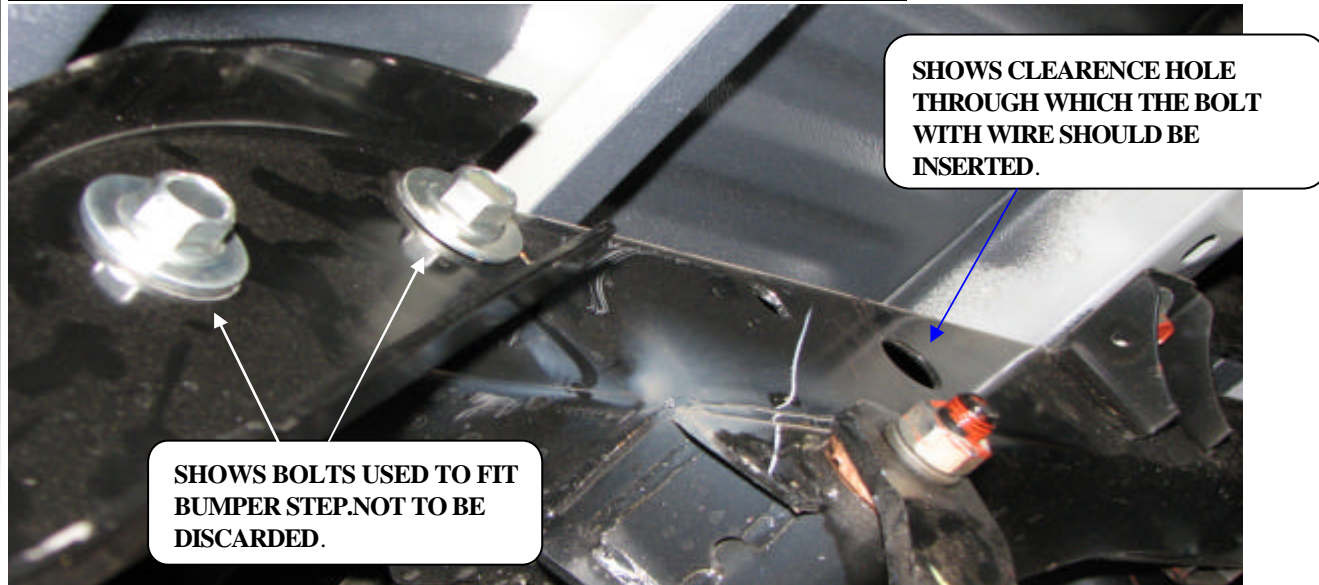
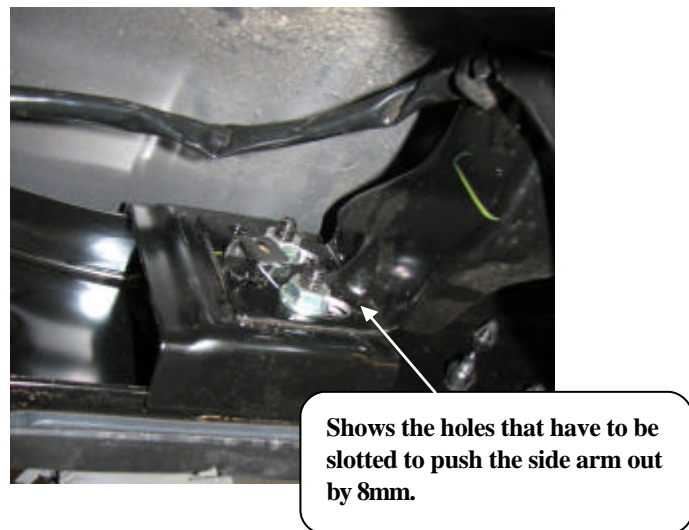

FIG 2: Passenger side arm of bumper step which has to be moved out using a packer.



FIG 3: Driver side arm of bumper step shown



TRAILBOSS

Towbar Fitting Instructions

To Suit TO SUIT MAZDA BT-50 & FORD RANGER TUB BODY 07-ON

NOTE: FITS BT-50 SDX VARIANTS WITH 8313 FIT KIT (ORDERED SEPERATELY)

Part Number QTMA433L

Rating 3000kg

FIG 4: SHOWS THE BRACKET THAT SHOULD BE REMOVED FROM PASSENGER SIDE ARM OF BUMPER BAR.



QTMA433 HITCH ASSEMBLY

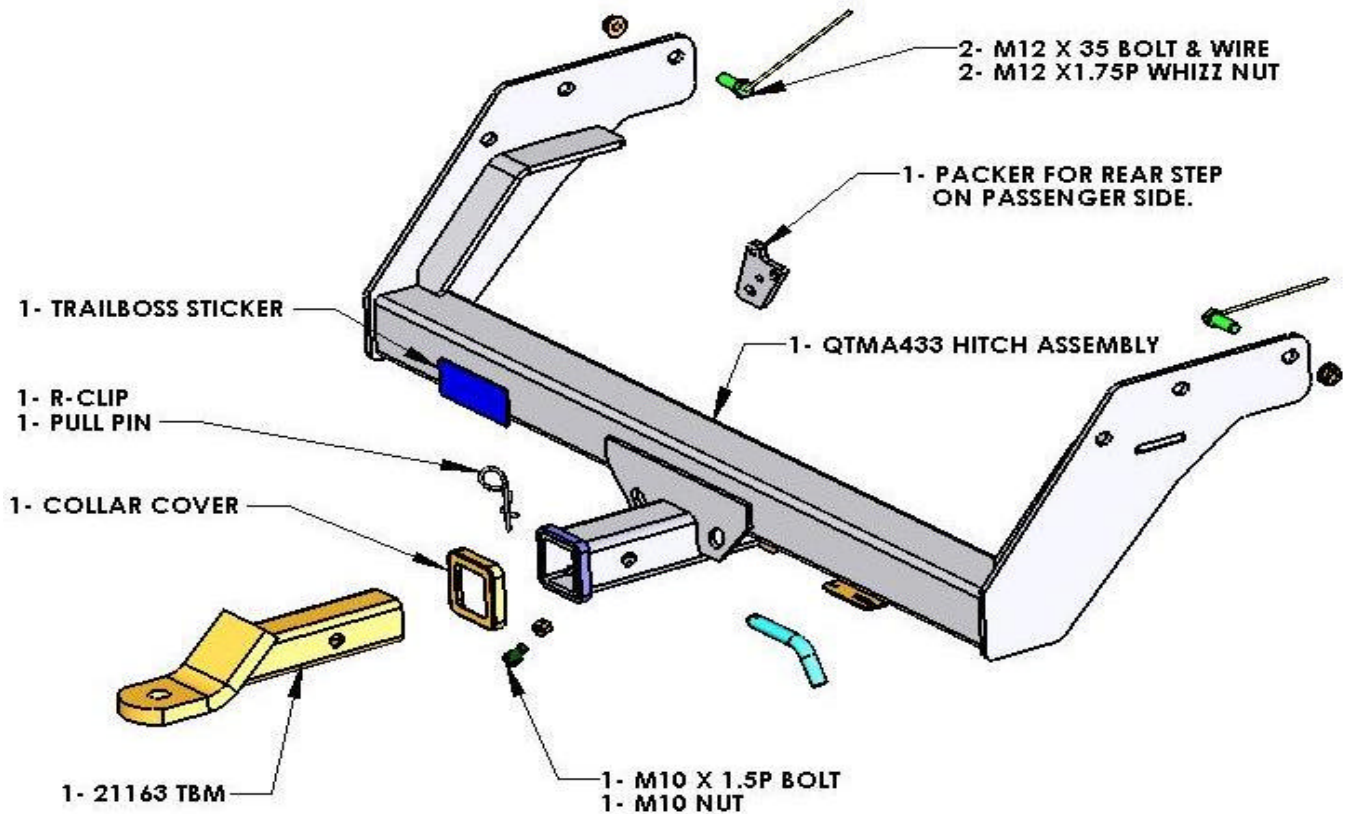



Wiring Loom Fitting Instructions
To Suit Mazda BT-50, Ford Ranger 4x4 & 4x2 Cab Chassis, Ford Ranger Tub Body
Part Number 100004-WL

Wiring Loom Installation Instructions

Mazda BT-50
Ford Ranger 4x4 & 4x2 Cab Chassis
Ford Ranger Tub Body
Part No: 100004-WL

Tail Harness Length Require: 1200mm

Wiring Loom Installation Time: Approx 20 Mins



Wiring Loom Fitting Instructions
To Suit Mazda BT-50, Ford Ranger 4x4 & 4x2 Cab Chassis, Ford Ranger Tub Body
Part Number 100004-WL

1. Remove both LHS & RHS tail lights by undoing 2x10mm bolts.
2. Disconnect both LHS and RHS tail lights and leave the connector on the outside of the vehicle.
3. From underneath the vehicle, route the Trailer Harness Patch (Part No: 100004-WL) from the LHS to the RHS tail light cavity, keeping the white 8-way connector to the RHS.
4. Connect the LHS and RHS of the Trailer Harness Patch to the vehicle tail lamp connectors.
5. Using the Tail Harness (length 1200mm), mount the Trailer socket using M4 fasteners and feed to the RHS tail light cavity.
6. Retrieve the Tail Harness from the RHS tail light cavity.
7. On the Tail Harness and mating connector, apply electrical grease or silicon on to the back of the connectors to make them water proof.
8. Connect the male and female connectors together.
9. Reconnect the LHS and RHS tail lights and refit the LHS and RHS tail light assemblies.
10. Secure all harnesses to the vehicle using cable ties.
11. Test the Trailer socket using a light board or multi-meter.
12. Secure the all harnesses using cables ties.
13. Refit all removed parts and secure all fasteners.
14. Place instructions in glove box after fitment.