



Towbar Fitting Instructions
 To Suit TO SUIT MAZDA BT-50 & FORD RANGER 2WD
 CAB CHASSIS 07-ON
 Part Number QTMA435L
 Rating 3000kg

WARNING:

Do not, drill, cut, weld or otherwise modify the Towbar.

If you are using electric welding on a motor vehicle, **always** check that the vehicle is not equipped with electronic engine or instrument management equipment. Failure to do so could **destroy** any onboard **computers**. If in doubt, check with the vehicle's manufacturer.



CAUTION TWO PERSON LIFT REQUIRED TO FIT THIS PRODUCT

1. Ensure all hardware items have been included.
2. Lift towbar up into position so as holes in towbar align with tapped holes in end of chassis.
3. Fit the bolts for the captives on both sides loosely.
4. Insert the bolt with wires provided, into the rearmost hole through the bigger clearance hole alongside & loosely fit with M12 whizz nuts provided.
5. Tighten to torque listing.
6. Towbar rating sticker to be conspicuously located on inside rear end of the driver's door. (See diagram below)

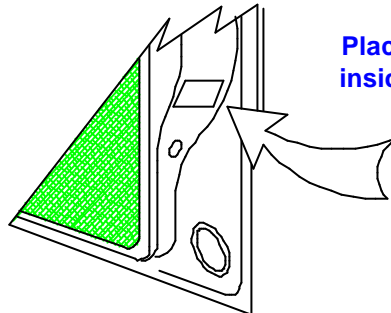

**Place load rating sticker
inside driver's door here**

RECOMMENDED ASSEMBLY TORQUE LISTING

Diameter Grade 8.8 Bolt

M6	9.5 Nm
M8	21.7 Nm
M10	43.4 Nm
M12	77.3 Nm
M16	189.8 Nm

FOR TOWING PURPOSES ONLY

For towing capacity details please refer to vehicle owner's manual or to the manufacturer. Overloading can void your warranties.

Tow bar Maintenance and Care.

Trailboss recommends that bolt torque's, as listed below, are routinely and regularly inspected and checked for correct tension. Replace any worn or defective parts.

We recommended to remove Tow Ball Mounts (TBM's, tongues or lugs) when not being used for any considerable length of time.

So as to avoid injury, when not towing it is suggested that the tongue, Pull Pin and R-clip are removed then stored in a safe, clean and dry place, away from excessive moisture.

Hitch Pull Pins and spring "R" clips are regularly checked for proper installation. Replace any worn or defective parts.

Towbar Fitting Instructions
To Suit TO SUIT MAZDA BT-50 & FORD RANGER 2WD
CAB CHASSIS 07-ON
Part Number QTMA435L
Rating 3000kg

QTMA435 HITCH ASSEMBLY

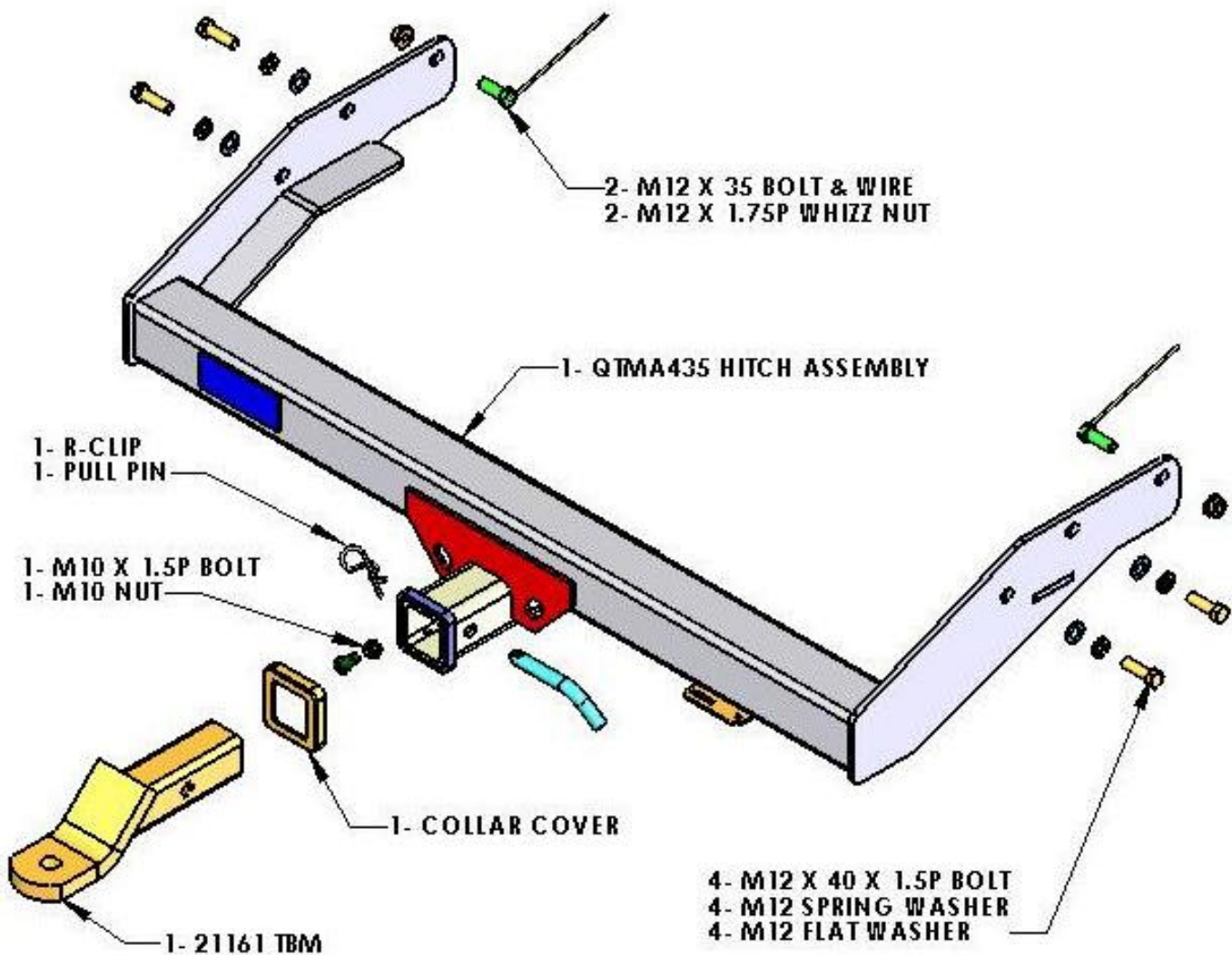



Wiring Loom Fitting Instructions
To Suit Mazda BT-50, Ford Ranger 4x4 & 4x2 Cab Chassis, Ford Ranger Tub Body
Part Number 100004-WL

Wiring Loom Installation Instructions

Mazda BT-50
Ford Ranger 4x4 & 4x2 Cab Chassis
Ford Ranger Tub Body
Part No: 100004-WL

Tail Harness Length Require: 1200mm

Wiring Loom Installation Time: Approx 20 Mins



Wiring Loom Fitting Instructions
To Suit Mazda BT-50, Ford Ranger 4x4 & 4x2 Cab Chassis, Ford Ranger Tub Body
Part Number 100004-WL

1. Remove both LHS & RHS tail lights by undoing 2x10mm bolts.
2. Disconnect both LHS and RHS tail lights and leave the connector on the outside of the vehicle.
3. From underneath the vehicle, route the Trailer Harness Patch (Part No: 100004-WL) from the LHS to the RHS tail light cavity, keeping the white 8-way connector to the RHS.
4. Connect the LHS and RHS of the Trailer Harness Patch to the vehicle tail lamp connectors.
5. Using the Tail Harness (length 1200mm), mount the Trailer socket using M4 fasteners and feed to the RHS tail light cavity.
6. Retrieve the Tail Harness from the RHS tail light cavity.
7. On the Tail Harness and mating connector, apply electrical grease or silicon on to the back of the connectors to make them water proof.
8. Connect the male and female connectors together.
9. Reconnect the LHS and RHS tail lights and refit the LHS and RHS tail light assemblies.
10. Secure all harnesses to the vehicle using cable ties.
11. Test the Trailer socket using a light board or multi-meter.
12. Secure the all harnesses using cables ties.
13. Refit all removed parts and secure all fasteners.
14. Place instructions in glove box after fitment.