

# TRAILBOSS

Towbar Fitting Instructions  
To Suit **MAZDA6 WAGON** 03-2010 on  
Part Number **QTMA653L**  
Rating **1500-120** kg

## **WARNING:**

1. Do not, drill, cut, weld or otherwise modify the tow bar.
2. If you are using electric welding on a motor vehicle, **always** check that the vehicle is not equipped with electronic engine or instrument management equipment. Failure to do so could **destroy** any onboard computers. If in doubt, check with the vehicle's manufacturer.

## **General:**

1. Ensure all hardware items have been included refer to assembly diagram.
2. It is recommended that the instructions are read through and completely understood before making any attempt to fit this product.
3. Be wary of any changes to vehicle designs or other accessories that may conflict with the installation of this product.
4. Before drilling ensure that the area is clear of fuel, electrical & other components.
5. All holes drilled into the body panels shall have all burrs & swarf removed then coated with a suitable rust preventative paint.
6. For vehicles that require the bumper to be cut. Ensure cut out area is in correct position on the vehicle prior to cutting the bumper.
7. The high tensile fasteners supplied with this product were used to achieve the specified rating. If replacement is required ensure that fasteners of the same rating & quality are used. Contact an authorized **Trailboss** dealer if further information is required.
8. Ensure that all hardware is fastened to torque list below check fasteners on regular basis.
9. Tow bar load rating sticker provided with this product shall be conspicuously located on inside rear end of the driver's door. **(See diagram below).**
10. Trailboss recommends that you check your tow ball to ensure that it complies with the Australian standards **AS 4177.2.**
11. **PLEASE NOTE:** It is advised to remove your lug or tbn when not actually towing so as to produce a clear view of the vehicles registration plate if obscured, and to also provide maximum available departure angle

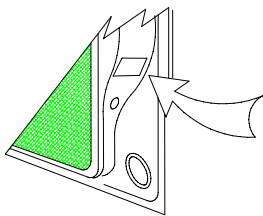

Place load rating sticker  
inside driver's door here

**FOR TRAILER TOWING PURPOSES ONLY**  
For towing capacity details please refer to vehicle owner's manual or to the manufacturer. Overloading can void your warranties.

## **RECOMMENDED ASSEMBLY TORQUE LISTING**

<u>Diameter</u>	<u>Grade 8.8 Bolt</u>
M6	9.5 Nm
M8	21.7 Nm
M10	43.4 Nm
M12	77.3Nm
M14	146 Nm
M16	189.8 Nm

## **Tow bar Maintenance and Care.**

Trailboss recommends that bolt torque's, as listed below, are routinely and regularly inspected and checked for correct tension. Replace any worn or defective parts.

We recommended to remove Tow Ball Mounts (TBM's, tongues or lugs) when not being used for any considerable length of time.

So as to avoid injury, when not towing it is suggested that the tongue, Pull Pin and R-clip are removed then stored in a safe, clean and dry place, away from excessive moisture.

Hitch Pull Pins and spring "R" clips are regularly checked for proper installation. Replace any worn or defective parts.

# TRAILBOSS

Towbar Fitting Instructions  
To Suit **MAZDA6 WAGON** 03-2010 on  
Part Number **QTMA653L**  
Rating **1500-120 kg**

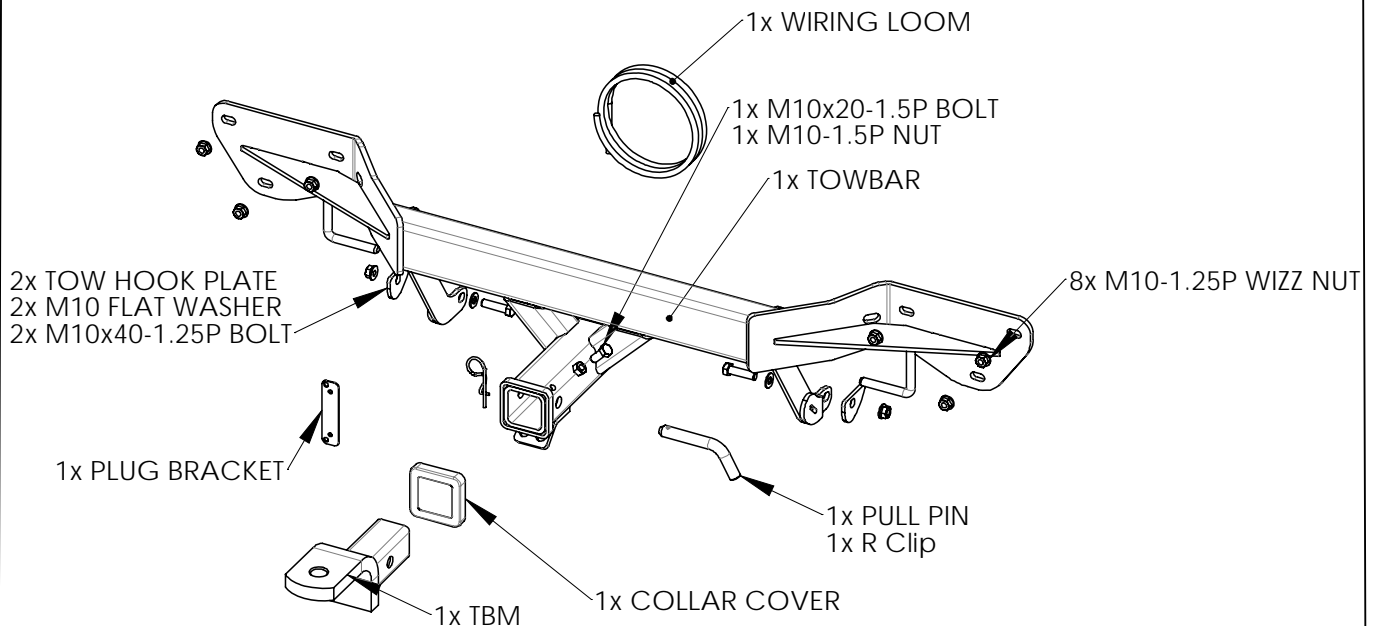

## 11. Remove bumper bar

- Remove 3 screws inside and 1 under rear mid guard on both sides.
- Remove 2 screws under the mud guard on both sides.
- Remove 2 plastic trim plugs under the bumper bar
- Remove taillight assembly by removing 3 nuts from inside vehicle.
- Remove 2 screws on top of the bumper.
- Remove 2 screws inside tailgate cavity.
- Disconnect any wiring attached to bumper bar before remove rear bumper.

## 12. Remove impact beam

- Remove four M10 nuts from each side of rear impact beam.
- Remove muffler hanger on both side.
- Remove and discard the rear impact beam.

## 13. Fitment the towbar via

- Position towbar against rear studs and secure with 6 M10x1.25 nuts supplied.
- Use M10x40 bolts, flat washer, tow hook plate, and M10x1.25 nuts provided to secure the tow hook mount.
- Torque all bolts and nuts to recommended torque refer page 1.
- Reinstall muffler hanger on both side.

Towbar Fitting Instructions  
To Suit **MAZDA6 WAGON** 03-2010 on  
Part Number **QTMA653L**  
Rating **1500-120** kg

14. Bumper cut detail

- a. Establish centre line of bumper bar then mark out per below.
- b. Cut section of bumper with modified hacksaw or similar device.
- c. Cut 74mm wide section from centre, 75mm from the top paint line and 60mm from the bottom of bumper as the cut point.
- f. Reinstall the bumper in reverse order.

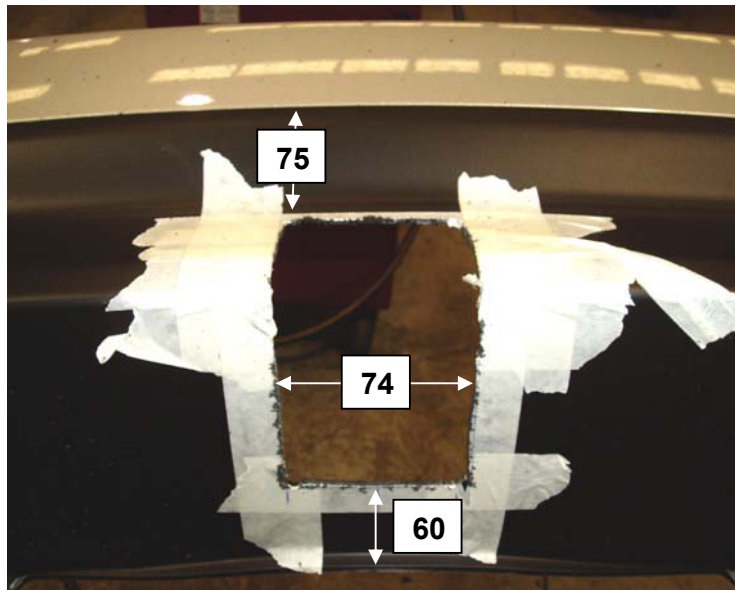



Wiring Loom Fitting Instructions  
To Suit Mazda GH12 Wagon  
Part Number 100347-WL

Wiring Loom Installation Instructions

Mazda 6 GH12  
Wagon  
Part No: 100347-WL

Tail Harness Length Required: 1200mm  
RPA Override Switch Part No: 04848 (If Fitted)

Wiring Loom Installation Time: Approx 40 Mins



Wiring Loom Fitting Instructions  
To Suit Mazda GH12 Wagon  
Part Number 100347-WL

1. Remove the bumper fascia by removing all of its fasteners.
2. At the rear of the vehicle luggage compartment remove the rear sunshade and the floor carpet. Fold down the rear seats.
3. Remove the rear floor cover.
4. Remove the rear trim and then the LHS and RHS tool trays.
5. Remove the rear passengers LHS door sill trim.
6. Remove the LHS luggage compartment upper trim by removing its fasteners (disconnect any connectors if applicable).
7. Remove the RHS luggage compartment upper trim by removing its fasteners (disconnect any connectors if applicable).
8. Remove the LHS luggage compartment trim by removing its fasteners (disconnect any connectors if applicable)
9. Remove the RHS luggage compartment trim by removing its fasteners (disconnect any connectors if applicable)
10. At the rear of the vehicle, remove the rear grommet. Drill out the grommet hole to Ø31mm. File down any rough or sharp edges and spray on rust inhibitor.
11. Mount the tail harness (tail length 1200mm) to the towbar mounting bracket using M4 fasteners (not supplied).
12. Route the tail harness connector into the grommet hole. Adjust the tail harness grommet into place ensuring it is seated correctly. Secure the tail harness grommet into place using a cable tie (not supplied).
13. In the luggage compartment, disconnect the LHS vehicle taillight assembly 2-way connectors and patch the trailer patch harness connectors in between.
14. Secure the trailer patch harness ground ring terminal to the vehicle grounding point.
15. Gain access to the vehicle harness wires in the area below the vehicle grounding point and secure the supplied ezy tap onto the vehicle harness BLACK/BLUE reverse wire. Connect the trailer patch harness terminal to the supplied ezy tap.
16. Route the harness across to the RHS and connect the trailer patch harness connector to the tail harness mating connector.
17. On the RHS of the vehicle, disconnect the RHS taillight assembly 2-way and 4-way connectors. Route the trailer patch harness 2-way and 4-way connectors to the RHS of the vehicle and patch them in between.
18. Test the Trailer socket using a light board or multi-meter.
19. Secure the all harnesses using cables ties (not supplied).



Wiring Loom Fitting Instructions  
To Suit Mazda GH12 Wagon  
Part Number 100347-WL

20. Refit all removed parts and secure all fasteners.

21. Place instructions in glove box after fitment.