

# TRAILBOSS

## Towbar Fitting Instructions To Suit **MAZDA CX-9 TC CL4** Part Number **QTMA660L** Rating **2000/100** kg

PLACE THESE INSTRUCTIONS IN THE VEHICLE'S GLOVEBOX AFTER INSTALLATION IS COMPLETED

### **WARNING:**

1. Do not, drill, cut, weld or otherwise modify the tow bar.
2. If you are using electric welding on a motor vehicle, **always** check that the vehicle is not equipped with electronic engine or instrument management equipment. Failure to do so could **destroy** any onboard computers. If in doubt, check with the vehicle's manufacturer.
3. The high tensile fasteners supplied with this product were used to achieve the specified rating. If replacement is required ensure that fasteners of the same rating & quality are used. Contact an authorised **Trailboss** dealer if further information is required.
4. If TBM is used in inverted position tow ball may make contact with rear tailgate when lowered, which could cause damage.

### **General:**

1. Ensure all hardware items have been included refer to assembly diagram.
2. It is recommended that the instructions are read through and completely understood before making any attempt to fit this product.
3. Be wary of any changes to vehicle designs or other accessories that may conflict with the installation of this product.
4. Before drilling ensure that the area is clear of fuel, electrical & other components.
5. All holes drilled into the body panels shall have all burrs & swarf removed then coated with a suitable rust preventative paint.
6. For vehicles that require the bumper to be cut. Ensure cut out area is in correct position on the vehicle prior to cutting the bumper.
7. The high tensile fasteners supplied with this product were used to achieve the specified rating. If replacement is required ensure that fasteners of the same rating & quality are used. Contact an authorized **Trailboss** dealer if further information is required.
8. Ensure that all hardware is fastened to torque list below check fasteners on regular basis.
9. Tow bar load rating sticker provided with this product shall be conspicuously located on inside rear end of the driver's door. **(See diagram below).**
10. Trailboss recommends that you check your tow ball to ensure that it complies with the Australian standards **AS 4177.2**.
11. **PLEASE NOTE:** It is advised to remove your LUG or TBM when not actually towing so as to produce a clear view of the vehicles registration plate if obscured, and to also provide maximum available departure angle

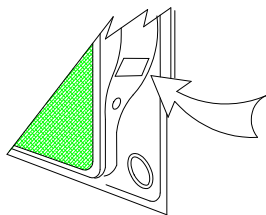

Place load rating sticker  
inside driver's door here

**FOR TRAILER TOWING PURPOSES ONLY**  
For towing capacity details please refer to vehicle owner's manual or to the manufacturer. Overloading can void your warranties.

### RECOMMENDED ASSEMBLY TORQUE LISTING

Diameter	Grade 8.8 Bolt
M6	9.5 Nm
M8	21.7 Nm
M10	43.4 Nm
M12	77.3Nm
M14	146 Nm
M16	189.8 Nm

### **Tow bar Maintenance and Care.**

Trailboss recommends that bolt torque's, as listed below, are routinely and regularly inspected and checked for correct tension. Replace any worn or defective parts.

We recommended to remove Tow Ball Mounts (TBM's, tongues or lugs) when not being used for any considerable length of time.

So as to avoid injury, when not towing it is suggested that the tongue, Pull Pin and R-clip are removed then stored in a safe, clean and dry place, away from excessive moisture.

Hitch Pull Pins and spring "R" clips are regularly checked for proper installation. Replace any worn or defective parts.

### **Cequent Customer Service**

Ph: 1800 812 017 Fax: 03 9898 3299

Email: info@cequent.com.au

Post: PO Box 4050, Dandenong South VIC 3175

# TRAILBOSS

Towbar Fitting Instructions  
 To Suit **MAZDA CX-9 TC CL4**  
 Part Number **QTMA660L**  
 Rating **2000/100 kg**

PLACE THESE INSTRUCTIONS IN THE VEHICLE'S GLOVEBOX AFTER INSTALLATION IS COMPLETED

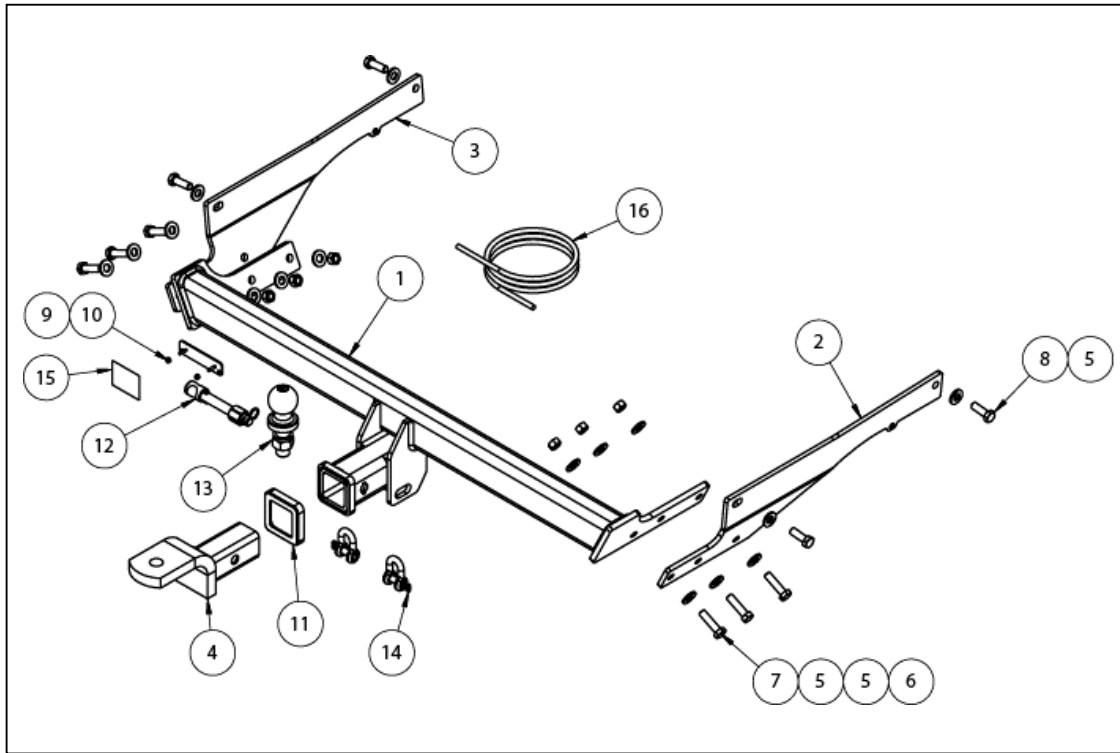

ITEM NO.	DESCRIPTION	QTY.
1	MAZDA CX-9 TUBE ASSY	1
2	SIDE ARM RH	1
3	SIDE ARM LH	1
4	TRAILER BALL MOUNT	1
5	WASHER FLAT 1/2"x1 1/8"x1/8"	16
6	HEX NUT PC8 M12x1.25	6
7	SET SCREW M12x45x1.25P	6
8	BOLT M12-1.25x35	4
9	PLUG BRACKET	1
10	NUT NYLOC M4-0.7 Z/P	2
11	HITCH BOX COLLAR COVER	1
12	SILENT HITCH PIN – SILVER	1
13	TOWBALL 50MM	1
14	"D" SHACKLE 10MM	2
15	ACRYLIC COMPLIANCE LABEL	1
16	WIRING LOOM	1

**Cequent Customer Service**  
 Ph: 1800 812 017 Fax: 03 9898 3299  
 Email: info@cequent.com.au  
 Post: PO Box 4050, Dandenong South VIC 3175

# TRAILBOSS

Towbar Fitting Instructions  
To Suit **MAZDA CX-9 TC CL4**  
Part Number **QTMA660L**  
Rating **2000/100 kg**

PLACE THESE INSTRUCTIONS IN THE VEHICLE'S GLOVEBOX AFTER INSTALLATION IS COMPLETED

1. Open rear door to expose the screw covers for the lights and the bumper.
2. Remove the covers (3 x LH and 3 x RH)



3. On LH side, remove 2 x screws securing the rear lights.
  4. Remove the 2 x screws securing the bump.
- Repeat for the other side.



5. In LH wheel arch remove 3 x scrivets, 2 x screws and 1 x plastic nut securing the bumper and plastic protector.
- Repeat for the other side.



**Cequent Customer Service**  
Ph: 1800 812 017 Fax: 03 9898 3299  
Email: [info@cequent.com.au](mailto:info@cequent.com.au)  
Post: PO Box 4050, Dandenong South VIC 3175

# TRAILBOSS

Towbar Fitting Instructions  
To Suit **MAZDA CX-9 TC CL4**  
Part Number **QTMA660L**  
Rating **2000/100 kg**

PLACE THESE INSTRUCTIONS IN THE VEHICLE'S GLOVEBOX AFTER INSTALLATION IS COMPLETED

6. On LHS under bumper remove 4 x screws and 1 x scrivet.



7. On RHS under bumper remove 2 x screws and 1 x scrivets securing the plastic protector.



8. Under vehicle remove the 2 x scrivets securing the bumper.



**Cequent Customer Service**  
Ph: 1800 812 017 Fax: 03 9898 3299  
Email: [info@cequent.com.au](mailto:info@cequent.com.au)  
Post: PO Box 4050, Dandenong South VIC 3175

# TRAILBOSS

Towbar Fitting Instructions  
To Suit **MAZDA CX-9 TC CL4**  
Part Number **QTMA660L**  
Rating **2000/100 kg**

PLACE THESE INSTRUCTIONS IN THE VEHICLE'S GLOVEBOX AFTER INSTALLATION IS COMPLETED

9. Carefully release wheel trim garnish (4 x panel clips) to expose 2 x scrivets and 1 x screw securing bumper.

**Be careful not to crease the trim garnish during this process.**

10. Remove the 2 x scrivets and 1 x screw.

Repeat for the other side.



11. On LHS remove the plastic protector by unclipping the 2 x clips located on the bumper.

Repeat for the other side.



12. Carefully peel away from the sides of the vehicle and remove the bumper. There is a small clip on the bumper in the light cavity that must be released.

**Note: There is a wiring harness fitted to a plastic bracket on the LH side inside the bumper. Disconnect the plug and remove the clip from the bracket.**



**Cequent Customer Service**

Ph: 1800 812 017 Fax: 03 9898 3299

Email: [info@cequent.com.au](mailto:info@cequent.com.au)

Post: PO Box 4050, Dandenong South VIC 3175

# TRAILBOSS

Towbar Fitting Instructions  
To Suit **MAZDA CX-9 TC CL4**  
Part Number **QTMA660L**  
Rating **2000/100 kg**

PLACE THESE INSTRUCTIONS IN THE VEHICLE'S GLOVEBOX AFTER INSTALLATION IS COMPLETED

13. On LH side chassis frame, remove the wiring harness clip from the chassis.
  14. Remove the tape to expose the 2 x towbar mounting hole positions.
  15. Clean the chassis frame side of excessive sealant using a scraper.
- Repeat for the other side.



16. Drop the exhaust by removing the 4 x hanger bracket rubbers (2 x LH and 2 x RH side). Support the exhaust with a strap.



17. Loosely secure the LH side arm to the LH chassis rail with 2 x M12 x 1.25 x 35 complete with 1 x washer.  
Attach the harness to the LH side arm lug with a cable tie (not supplied).
- Repeat for the other side.



**Cequent Customer Service**  
Ph: 1800 812 017 Fax: 03 9898 3299  
Email: [info@cequent.com.au](mailto:info@cequent.com.au)  
Post: PO Box 4050, Dandenong South VIC 3175

# TRAILBOSS

Towbar Fitting Instructions  
To Suit **MAZDA CX-9 TC CL4**  
Part Number **QTMA660L**  
Rating **2000/100 kg**

PLACE THESE INSTRUCTIONS IN THE VEHICLE'S GLOVEBOX AFTER INSTALLATION IS COMPLETED

18. Fit the crosstube to the side arm and loosely secure with 3 x M12 x1.25 x 70 bolts complete with 2 x washers and 1 x nut per bolt.

Repeat for the other side.



19. Torque the bolts starting with the side arms to the chassis rail (LH and RH sides) followed by the side arms to the crosstube (LH and RH sides).

**BOLT TORQUE: 125Nm**

20. On the outside underside of the bumper, locate the bumper centre line, mark out and cut the bumper cut 145mm long (from the bottom edge, following the curve of the bumper) x 90mm wide as depicted.

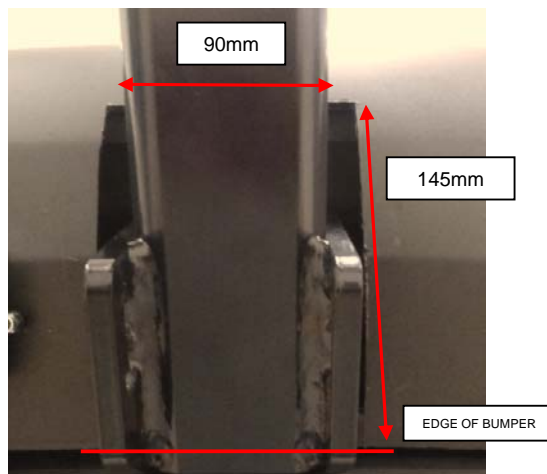

**Cequent Customer Service**

Ph: 1800 812 017 Fax: 03 9898 3299

Email: [info@cequent.com.au](mailto:info@cequent.com.au)

Post: PO Box 4050, Dandenong South VIC 3175

# TRAILBOSS

Towbar Fitting Instructions  
To Suit **MAZDA CX-9 TC CL4**  
Part Number **QTMA660L**  
Rating **2000/100 kg**

PLACE THESE INSTRUCTIONS IN THE VEHICLE'S GLOVEBOX AFTER INSTALLATION IS COMPLETED

21. Determine an appropriate position for the plug bracket. Mark out and drill 2x  $\varnothing 5$ mm holes 69mm apart on bumper skin to support plug bracket. Feed bracket threads through drilled holes prior to reinstalling bumper.

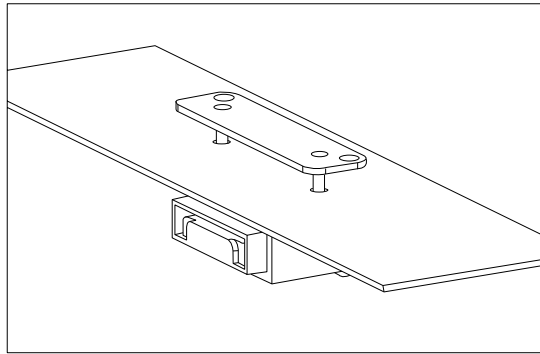

22. Refit the bumper and other components following steps 12 to 1.
23. Apply the load rating label to the door (see page 2) and place the fitting instructions in the glove box on completion.

**Cequent Customer Service**  
Ph: 1800 812 017 Fax: 03 9898 3299  
Email: [info@cequent.com.au](mailto:info@cequent.com.au)  
Post: PO Box 4050, Dandenong South VIC 3175





Wiring Loom Fitting Instructions  
To Suit Mazda CX-9 (QTMA660L)  
Part Number 201497-WL

## Wiring Loom Installation Instructions

Mazda CX-9  
Part No: 201497-WL  
ECU: 04826

Tail Harness Length Required: 1800mm  
RPA Disable Harness: 04944

Wiring Loom Installation Time: Approx 40 Mins

**Important**



Due to possible vehicle variations, always confirm any noted vehicle colour wires with a multi-meter to ensure the correct function is identified before soldering or scotch locking. For vehicle wires denoted with two colours (example; RED/GREEN) the first colour will always be the main wire colour while the second colour is the thinner trace colour on the wire.



Wiring Loom Fitting Instructions  
To Suit Mazda CX-9 (QTMA660L)  
Part Number 201497-WL

1. In the luggage compartment, fold down the rear seats.
2. Remove the floor mat and the LHS and RHS floor carpet covers.
3. Unclip and remove both LHS and RHS lower rear quarter storage trays.
4. Remove the luggage compartment rear trim.
5. Remove all the fasteners holding in the LHS and RHS luggage compartment trims (seven on each side) and disconnect the 12V connector from the RHS.
6. Remove both LHS and RHS trims from the vehicle.
7. Remove the RHS upper 'D' pillar trim clip and then remove the upper trim.
8. At the rear interior of the vehicle, dislodge the roof lining by removing the two clips.
9. At the exterior RHS rear quarter, remove the grommet sitting lower down from the tail light.
10. Inside the vehicle, route the trailer patch harness (P/No:201497-WL) break-out connector to the vehicle mating break-out connector.
11. Locate the ground point on the RHS wheel arch area. Secure the trailer patch ground ring terminal to the vehicle grounding point using the existing vehicle fastener.
12. Using an alcohol wipe (not supplied), clean the sheet metal inner skin exterior side located behind the break out connector and grounding point area. This is where the ECU will be mounted.
13. Connect the trailer patch connector to the ECU (P/No: 04826). Remove the backing from the back of the ECU and mount the ECU onto the sheet metal area. **Ensure ECU is mounted with the connector pointing downwards.**
14. Appropriately route the trailer patch terminal branch up along the 'D' pillar and into the head lining.
15. Locate the vehicle harness connectors in the roof lining.
16. Using a multi-meter, locate the reverse wire signal from the vehicle connector.
17. Connect the ezy-tap to the located vehicle wire signal, then connect the trailer patch terminal to the ezy-tap.
18. At the rear exterior of the vehicle, mount the tail harness socket to the towbar mounting bracket using M4 fasteners (not supplied).
19. Route the tail harness (tail length: 1800mm) across the RHS and up into the exposed grommet hole. Adjust the trailer patch harness grommet so that it is seated correctly and cable tie (not supplied) in place.



Wiring Loom Fitting Instructions  
To Suit Mazda CX-9 (QTMA660L)  
Part Number 201497-WL

20. Connect the tail harness 8-way connector to the trailer patch 8-way mating connector.
21. To enable RPA cut-off, crimp the tail harness GREY and GREY/BLACK wires to the trailer patch mating GREY and GREY/BLACK wires.
22. Test the Trailer Harness function using a light board or multimeter.
23. Secure all harnesses using cable ties (not supplied).
24. Re-fit removed parts and secure all fasteners, ensuring there are no squeaks or rattles.
25. Place the instructions in the glove box after fitment.



# FITTING INSTRUCTIONS

## Silent Anti-Rattle Hitch Pin (PR0001)

• These fitting instructions are supplied to ensure understanding of how the HITCH PIN should be fitted and used correctly.

• Once installed, we recommend **ALL** instructions are kept and placed in the vehicle glove box.

**NOTE: Routine maintenance and inspection of the towbar & HITCH PIN is required. Regularly inspect for wear and check the tightness of the Hitch Pin. Follow instructions below to retighten the nut when necessary.**

**\*Do not tow with your vehicle if the R CLIP or the HITCH PIN is loose or missing. Replacement parts are available from your Pro Series Distributor.**

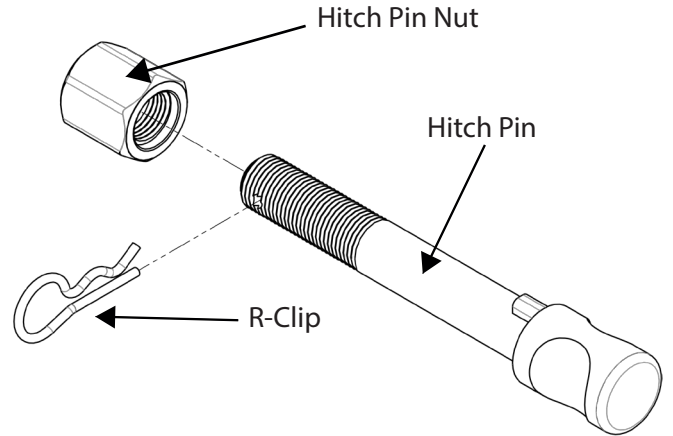

Fig 1. Silent Anti-Rattle Hitch Pin assembly

### STEP 1

Insert Trailer Ball Mount (TBM) into towbar HITCHBOX, aligning hole in TBM SHANK with hole in HITCHBOX (Fig 2).

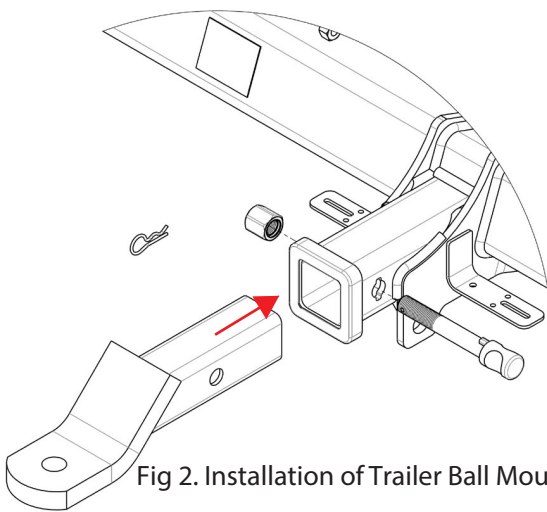

Fig 2. Installation of Trailer Ball Mount

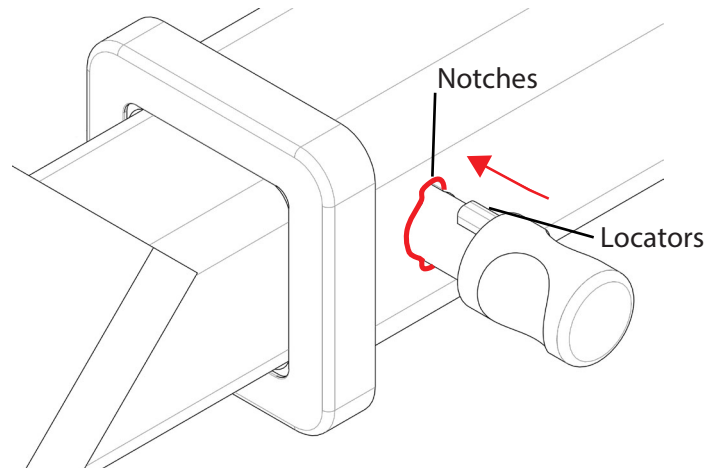

Fig 3. Silent Anti-Rattle Hitch Pin orientation

### STEP 2

Insert HITCH PIN through hole in HITCHBOX and hole in TBM SHANK; ensure the LOCATORS are inserted into the NOTCHES in the HITCHBOX (Fig. 3).

### STEP 3

Screw HITCH PIN NUT onto HITCH PIN ; tighten HITCH PIN NUT until finger tight, ensuring TBM is restrained from movement.

### STEP 4

Tighten HITCH PIN NUT by turning nut a further 1/8th of a turn in the clockwise direction using a 24mm spanner (Fig. 4).

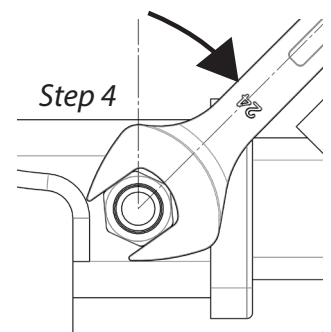

Fig 4. Tightening of Silent Anti-Rattle Hitch Pin Nut

### STEP 5

Install HITCH PIN R CLIP through the hole on the HITCH PIN (Fig. 1).