

# TRAILBOSS

Towbar Fitting Instructions  
To Suit **MAZDA CX-8 CL4**  
Part Number **QTMA662L**  
Rating **2000/100 kg**

PLACE THESE INSTRUCTIONS IN THE VEHICLE'S GLOVEBOX AFTER INSTALLATION IS COMPLETED

## **WARNING:**

1. Do not, drill, cut, weld or otherwise modify the tow bar.
2. If you are using electric welding on a motor vehicle, **always** check that the vehicle is not equipped with electronic engine or instrument management equipment. Failure to do so could **destroy** any onboard computers. If in doubt, check with the vehicle's manufacturer.
3. The high tensile fasteners supplied with this product were used to achieve the specified rating. If replacement is required ensure that fasteners of the same rating & quality are used. Contact an authorised **Trailboss** dealer if further information is required.
4. If TBM is used in inverted position tow ball may make contact with rear tailgate when lowered, which could cause damage.

## **General:**

1. Ensure all hardware items have been included refer to assembly diagram.
2. It is recommended that the instructions are read through and completely understood before making any attempt to fit this product.
3. Be wary of any changes to vehicle designs or other accessories that may conflict with the installation of this product.
4. Before drilling ensure that the area is clear of fuel, electrical & other components.
5. All holes drilled into the body panels shall have all burrs & swarf removed then coated with a suitable rust preventative paint.
6. For vehicles that require the bumper to be cut. Ensure cut out area is in correct position on the vehicle prior to cutting the bumper.
7. The high tensile fasteners supplied with this product were used to achieve the specified rating. If replacement is required ensure that fasteners of the same rating & quality are used. Contact an authorized **Trailboss** dealer if further information is required.
8. Ensure that all hardware is fastened to torque list below check fasteners on regular basis.
9. Tow bar load rating sticker provided with this product shall be conspicuously located on inside rear end of the driver's door. **(See diagram below).**
10. Trailboss recommends that you check your tow ball to ensure that it complies with the Australian standards **AS 4177.2**.
11. **PLEASE NOTE:** It is advised to remove your LUG or TBM when not actually towing so as to produce a clear view of the vehicles registration plate if obscured, and to also provide maximum available departure angle

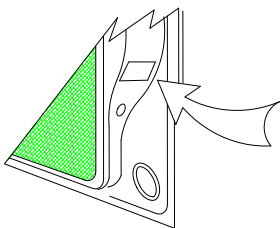

Place load rating sticker  
inside driver's door here

**FOR TRAILER TOWING PURPOSES ONLY**  
For towing capacity details please refer to vehicle owner's manual or to the manufacturer. Overloading can void your warranty.

### RECOMMENDED ASSEMBLY TORQUE LISTING

Diameter	Grade 8.8 Bolt
M6	9.5 Nm
M8	21.7 Nm
M10	43.4 Nm
M12	77.3Nm
M14	146 Nm

## **Tow bar Maintenance and Care.**

Trailboss recommends that bolt torque's, as listed below, are routinely and regularly inspected and checked for correct tension. Replace any worn or defective parts.

We recommended to remove Tow Ball Mounts (TBM's, tongues or lugs) when not being used for any considerable length of time.

So as to avoid injury, when not towing it is suggested that the tongue, Pull Pin and R-clip are removed then stored in a safe, clean and dry place, away from excessive moisture.

Hitch Pull Pins and spring "R" clips are regularly checked for proper installation. Replace any worn or defective parts.

**Cequent Customer Service**  
Ph: 1800 812 017 Fax: 03 9898 3299  
Email: info@cequent.com.au  
Post: PO Box 4050, Dandenong South VIC 3175

# TRAILBOSS

Towbar Fitting Instructions  
 To Suit **MAZDA CX-8 CL4**  
 Part Number **QTMA662L**  
 Rating **2000/100 kg**

PLACE THESE INSTRUCTIONS IN THE VEHICLE'S GLOVEBOX AFTER INSTALLATION IS COMPLETED

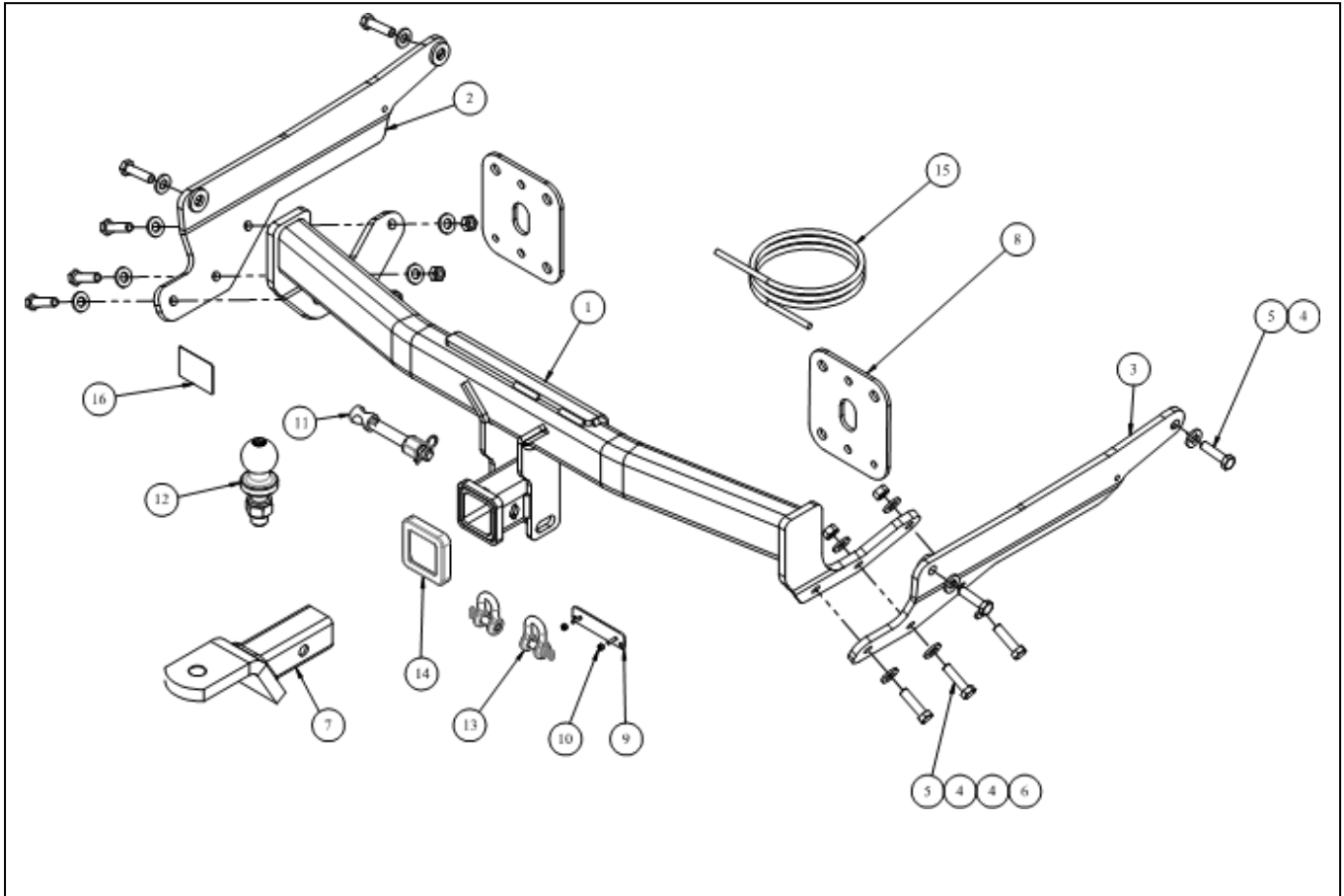

ITEM	DESCRIPTION	QTY
1	MAZDA CX8 CL4 WELDED ASSY	1
2	SIDE ARM ASSY LH	1
3	SIDE ARM ASSY RH	1
4	WASHER PLAIN 1/2X1-1/8X16G	16
5	SET SCREW HEX HD M12 X 45 X 1.25P	10
6	NUT HEX HD M12 X 1.25P G8	6
7	CLASS 4 TBM	1
8	BACK PANEL PLATE	2

ITEM	DESCRIPTION	QTY
9	PLUG BRACKET	1
10	NUT NYLON LOCK HEX HD M4X0.7P	2
11	SILENT HITCH PIN - SILVER	1
12	TOWBALL 50MM CHROME 3500K	1
13	"D" SHACKLE 10mm	2
14	HITCH BOX COLLAR COVER	1
15	WIRING LOOM	1
16	ACRYLIC COMPLIANCE LABEL	1

**Cequent Customer Service**  
 Ph: 1800 812 017 Fax: 03 9898 3299  
 Email: [info@cequent.com.au](mailto:info@cequent.com.au)  
 Post: PO Box 4050, Dandenong South VIC 3175

# TRAILBOSS

Towbar Fitting Instructions  
To Suit **MAZDA CX-8 CL4**  
Part Number **QTMA662L**  
Rating **2000/100 kg**

PLACE THESE INSTRUCTIONS IN THE VEHICLE'S GLOVEBOX AFTER INSTALLATION IS COMPLETED

1. Open tailgate, lift exposed cover and remove 1 x Philips screw.
2. Remove tailgate stopper secured with 1 x Torx screw.
3. Lift the tail light cover and remove exposed 2 x Philip screws.  
Remove tail light by pulling rearwards and support tail light in vehicle (harness cannot be disconnected).

Repeat for other side.

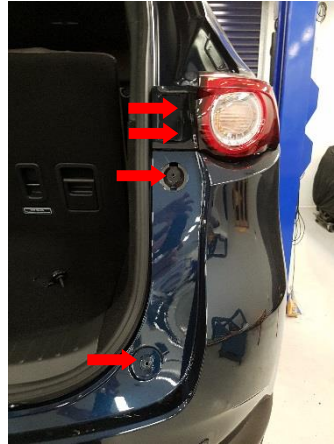

4. In wheel arch remove 3 x scrivets and 1 x clip.

Repeat for other side.



5. Pull wheel arch skirt outwards to reveal 2 x scrivets and 1 x screw.
6. Remove the exposed 2 x scrivets and 1 x screw.
7. Release 2 x clips on bumper.

Repeat for other side.



**Cequent Customer Service**

Ph: 1800 812 017 Fax: 03 9898 3299

Email: [info@cequent.com.au](mailto:info@cequent.com.au)

Post: PO Box 4050, Dandenong South VIC 3175

# TRAILBOSS

Towbar Fitting Instructions  
To Suit **MAZDA CX-8 CL4**  
Part Number **QTMA662L**  
Rating **2000/100 kg**

PLACE THESE INSTRUCTIONS IN THE VEHICLE'S GLOVEBOX AFTER INSTALLATION IS COMPLETED

8. Under vehicle, remove the LH and RH side body trim secured with 2 x screws and 1 x scrivet.
9. Remove 2 x scrivets along bumper.



10. Disconnect and remove wiring harness from the vehicle mounting (located inside bumper on the LH side).
11. Peel away bumper from the ends and remove from vehicle.



12. Remove and discard the impact beam, secured with 4 x flange nuts per side. Retain the nuts for later use.



**Cequent Customer Service**  
Ph: 1800 812 017 Fax: 03 9898 3299  
Email: [info@cequent.com.au](mailto:info@cequent.com.au)  
Post: PO Box 4050, Dandenong South VIC 3175

# TRAILBOSS

Towbar Fitting Instructions  
To Suit MAZDA CX-8 CL4  
Part Number QTMA662L  
Rating 2000/100 kg

PLACE THESE INSTRUCTIONS IN THE VEHICLE'S GLOVEBOX AFTER INSTALLATION IS COMPLETED

13. On chassis rail peel off the tape to reveal the 2 x mounting positions.

14. Unclip the wiring harness from the chassis rail.

Repeat for other side.

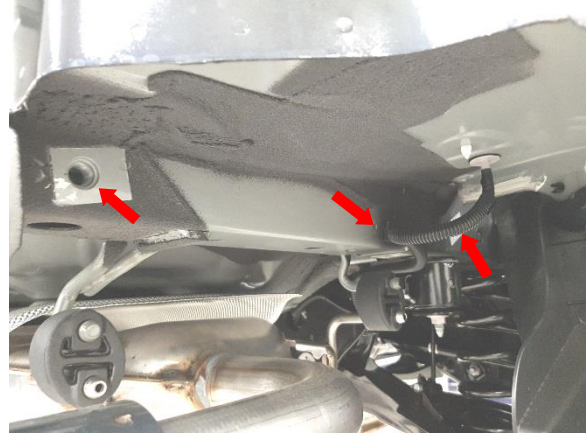

15. Loosely secure side arm to the chassis rail with 2 x M12 bolts complete with 1 x washer per bolt.

16. Cable tie (not provided) the unclipped harness to small hole on the side arm.

Repeat for other side.

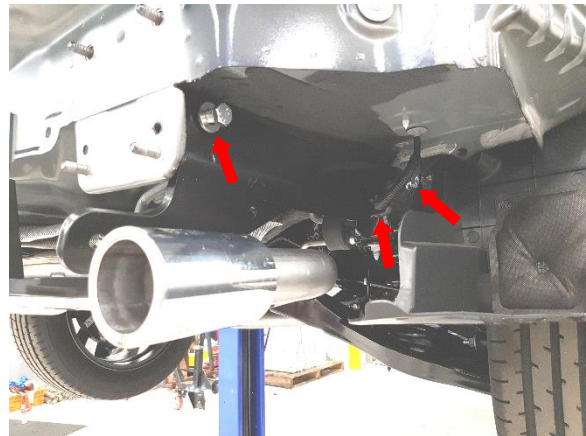

17. Fit the back plates to the impact beam mounting studs and secure with the 4 x retained nuts per side.

**Torque the impact beam nuts to 40Nm.**

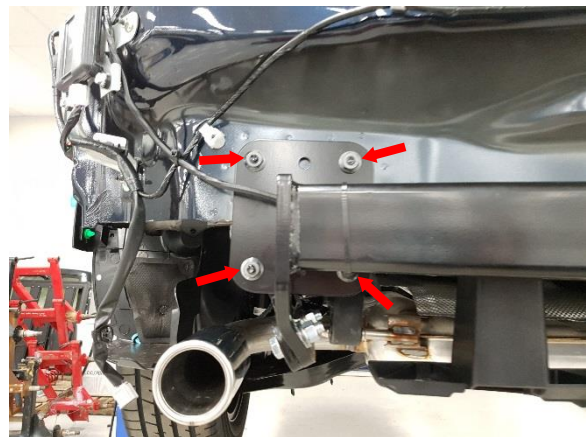

## Cequent Customer Service

Ph: 1800 812 017 Fax: 03 9898 3299

Email: [info@cequent.com.au](mailto:info@cequent.com.au)

Post: PO Box 4050, Dandenong South VIC 3175

# TRAILBOSS

Towbar Fitting Instructions  
To Suit **MAZDA CX-8 CL4**  
Part Number **QTMA662L**  
Rating **2000/100 kg**

PLACE THESE INSTRUCTIONS IN THE VEHICLE'S GLOVEBOX AFTER INSTALLATION IS COMPLETED

18. Lift the crosstube to the side arms and loosely secure to the side arms with 3 x M12 Bolts complete with 2 x washers and 1 x nut per bolt for each side.

**Torque all M12 fasteners to 125Nm.**



19. For the bumper cut.  
Locate the centre of the bumper, and on the outside, mark off and cut out 90mm wide by 120mm long measured from the bottom edge of the bumper. (Cut should stop about 15mm below the bottom styleline)  
Deburr and smooth off cut edges.

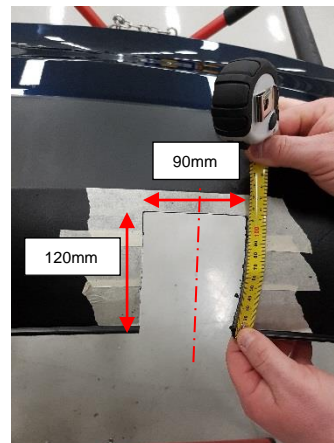

20. Determine an appropriate position for the plug bracket. Mark out and drill 2x  $\varnothing 5\text{mm}$  holes 69mm apart on bumper skin to support plug bracket.
21. Reattach bumper and removed components by following steps 1-10 in reverse.

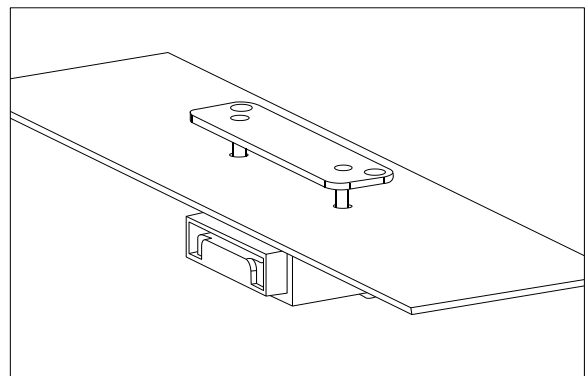

**Cequent Customer Service**  
Ph: 1800 812 017 Fax: 03 9898 3299  
Email: [info@cequent.com.au](mailto:info@cequent.com.au)  
Post: PO Box 4050, Dandenong South VIC 3175



Wiring Loom Fitting Instructions  
To Suit Mazda CX-8  
Part Number 102066-WL

### Wiring Loom Installation Instructions

Mazda CX-8

Part No: 102066-WL

ECU: 04826

Tail Harness Length Required: 1800mm

RPA Disable Information: Use part WLT025

Electric Brake Wire Location: Near Blue Connector

Wiring Loom Installation Time: Approx 60 Mins

**Cequent Customer Service**

Ph: 1800 812 017 Fax: 03 9898 3299

Email: [info@cequent.com.au](mailto:info@cequent.com.au)

Post: PO Box 4050, Dandenong South VIC 3175



Wiring Loom Fitting Instructions  
To Suit Mazda CX-8  
Part Number 102066-WL

1. In the engine bay, disconnect the negative battery.
2. In the boot, fold down the third row seats.
3. Remove the centre storage tray cover.
4. Remove the LHS and RHS storage tray covers.
5. Remove the spare wheel cover.
6. Remove the LHS and RHS tool tray.
7. On the rear scuff plate (1), use a plastic trim removal tool to pop out the centre of the two clips and remove from scuff plate.
8. Remove the rear scuff plate by pulling in an upwards direction.
9. Remove the vehicle jack.
10. Remove the last tool tray.
11. On the LHS, remove the trim clip under the previously removed scuff plate.  
**Repeat for RHS.**
12. Remove the 10mm bolt behind the 'D' pillar luggage securing hood cover.  
**Repeat for RHS.**
13. Pop the centre cover off the luggage securing clip near the rear ventilation vent.  
**Repeat for RHS.**
14. Remove 10mm bolt behind the cover.  
**Repeat for RHS.**
15. Fold LHS trim in towards the centre of the vehicle.
16. Remove the LHS sound deadening carpet enough to gain access to the tail lamp connectors.
17. Patch in the LHS mating connectors on the trailer patch (102066-WL) to the mating LHS tail light connectors on the vehicle.
18. Connect the ground wire ring terminal to the vehicle earthing point.
19. Route the T section of the harness along the existing vehicle loom towards the RHS.
20. Fold RHS trim in towards the centre of the vehicle and remove the sound deadening carpet covering the tail lamp connectors.
21. Patch in the RHS mating connectors on the trailer Patch to the mating RHS tail light connectors on the vehicle.

**Cequent Customer Service**  
Ph: 1800 812 017 Fax: 03 9898 3299  
Email: [info@cequent.com.au](mailto:info@cequent.com.au)  
Post: PO Box 4050, Dandenong South VIC 3175





Wiring Loom Fitting Instructions  
To Suit Mazda CX-8  
Part Number 102066-WL

22. On the LHS, using an alcohol wipe, clean the LHS inner sheet metal area and the underside of the ECU (04826).
23. Connect the trailer patch 12-way connector to the ECU.
24. Apply double sided tape to the ECU and secure it to the vehicle sheet metal.  
**Note: Mount the ECU, ensuring the connector is orientated downwards.**
25. Remove the LHS front and rear passenger scuff trim.
26. Route both the orange power wire and RPA disable patch down the LHS of the vehicle towards the LHS kick panel.  
**Note: To avoid entire removal of trim, utilise a guide wire.**
27. In the passenger seat area, remove the kick panel trim by releasing the nut on the firewall.
28. Remove the glove box by disconnecting the damping rod and then squeezing both sides to release.
29. Insert the supplied 20 Amp Fuse into the Add-A-Fuse and then insert the Add-A-Fuse into the blank fuse location in the orientation shown.
30. Connect the Add-A-Fuse to the mating connector on the power wire.  
**Note: To maintain correct electrical operation, ensure you insert the fuse adaptor into the allocated slot and in the orientation shown.**
31. Route the Reverse Park Assist disable patch connectors up towards the Parking Assist Module above the glove box.
32. Disconnect the connector from the ECU and patch in the mating T patch connectors into the vehicle ECU and the vehicle harness.
33. With the rear bumper removed, below the LHS tail lamp, locate the 30mm blanking grommet cover and remove.
34. Secure tail harness (Part number: WLT025) to tow bar.
35. Route tail harness up through chassis rail and previously removed vehicle blanking grommet.
36. Seat grommet in 30mm blanking hole and route to trailer harness blue connector on wiring loom.  
**Note: Keep harness routing clear of all sharp edges, moving parts and places of extreme heat.**  
**Note: Ensure grommet is seated correctly and makes a good seal.**
37. Connect the tail harness 8-way connector to the trailer patch mating 8-way connector.

**Cequent Customer Service**  
Ph: 1800 812 017 Fax: 03 9898 3299  
Email: [info@cequent.com.au](mailto:info@cequent.com.au)  
Post: PO Box 4050, Dandenong South VIC 3175



Wiring Loom Fitting Instructions  
To Suit Mazda CX-8  
Part Number 102066-WL

38. Cut-off, crimp the tail harness GREY and GREY/BLACK wires to the trailer patch matching White and GREY/BLACK wires.
39. Secure all harness using supplied Cable Ties.
40. Test the trailer patch function using a light board or multi-meter.
41. Re-fit all removed parts and secure all fasteners, ensuring there are no squeaks or rattles.
42. Place the fitting instructions in the glove box after fitment.

**Cequent Customer Service**  
Ph: 1800 812 017 Fax: 03 9898 3299  
Email: [info@cequent.com.au](mailto:info@cequent.com.au)  
Post: PO Box 4050, Dandenong South VIC 3175



# FITTING INSTRUCTIONS

## Silent Anti-Rattle Hitch Pin (PR0001)

• These fitting instructions are supplied to ensure understanding of how the HITCH PIN should be fitted and used correctly.

• Once installed, we recommend **ALL** instructions are kept and placed in the vehicle glove box.

**NOTE: Routine maintenance and inspection of the towbar & HITCH PIN is required. Regularly inspect for wear and check the tightness of the Hitch Pin. Follow instructions below to retighten the nut when necessary.**

**\*Do not tow with your vehicle if the R CLIP or the HITCH PIN is loose or missing. Replacement parts are available from your Pro Series Distributor.**

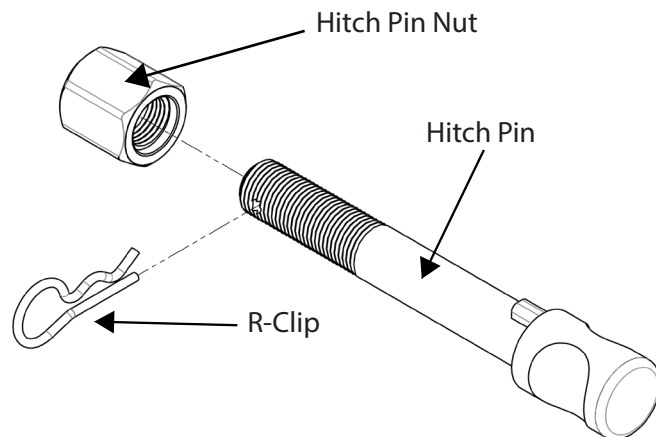

Fig 1. Silent Anti-Rattle Hitch Pin assembly

### STEP 1

Insert Trailer Ball Mount (TBM) into towbar HITCHBOX, aligning hole in TBM SHANK with hole in HITCHBOX (Fig 2).

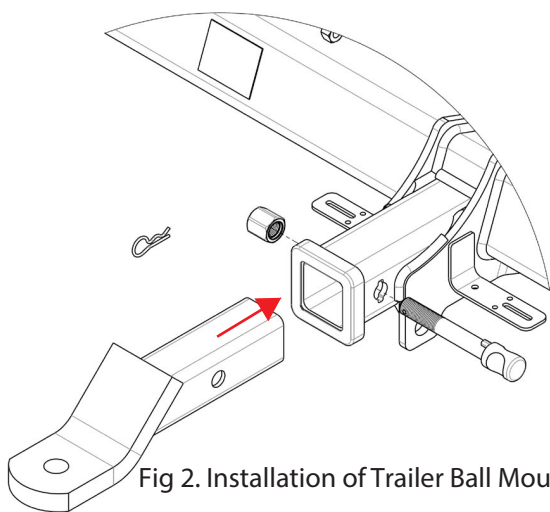

Fig 2. Installation of Trailer Ball Mount

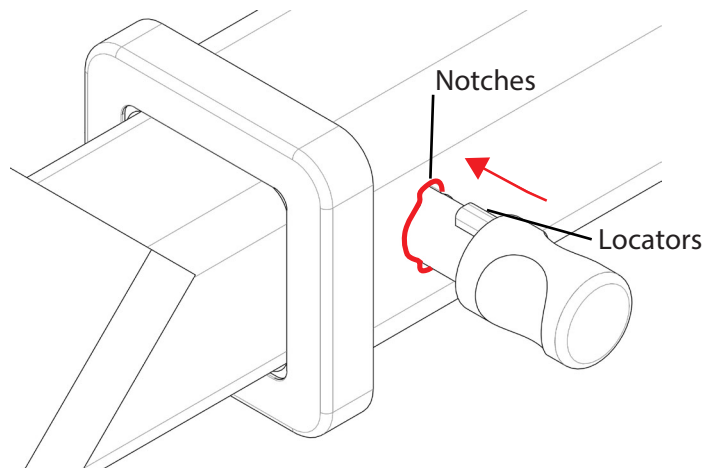

Fig 3. Silent Anti-Rattle Hitch Pin orientation

### STEP 2

Insert HITCH PIN through hole in HITCHBOX and hole in TBM SHANK; ensure the LOCATORS are inserted into the NOTCHES in the HITCHBOX (Fig. 3).

### STEP 3

Screw HITCH PIN NUT onto HITCH PIN ; tighten HITCH PIN NUT until finger tight, ensuring TBM is restrained from movement.

### STEP 4

Tighten HITCH PIN NUT by turning nut a further 1/8th of a turn in the clockwise direction using a 24mm spanner (Fig. 4).

### STEP 5

Install HITCH PIN R CLIP through the hole on the HITCH PIN (Fig. 1).

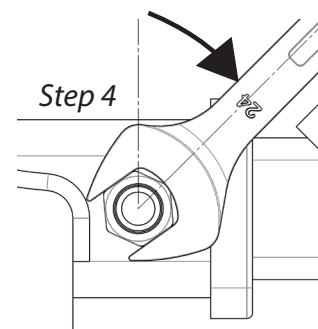

Fig 4. Tightening of Silent Anti-Rattle Hitch Pin Nut