



Tow bar Fitting Instructions
To Suit LAND ROVER FREE LANDER 3-04-ON
Part Number QTRV14
Rating 2500Kg

- 1 Ensure all hardware items have been included.
- 2 Remove upper tail lights, via 6-Torx screws.
- 3 Remove plastic trim above wheel arch, via 4-Torx screws
- 4 Remove bumper bar via removal of: -
 - a) 4-Torx screws on underside of bumper.
 - b) 6-Torx screws in wheel arches.
 - c) 5-plastic trim buttons on upper side of bumper.
 - d) 2-Torx screws in tail light cavity.
 - e) 2-Torx screws in plastic trim cavity.
- 5 Remove two tabs from bottom face of rear cross member, to expose cross tube mounting points.
- 6 To aid fitment, the rear muffler may be removed via 2-rubber hangers and one clamp.
- 7 Remove 2-lowest bolts from inner side of tow hook and discard bolts.
- 8 Position tow bar and fit 4-M10x30 bolts through side plates into captive nuts of chassis, loosely.
- 9 Fit 2-M12x70 bolts through clearance holes in cross tube into the chassis cross member.
- 10 Tighten bolts in 8 & 9 above.
- 11 Using side plates tabs as guides, drill M10 up through bottom face of chassis rail, both sides of car.
- 12 Insert tapped plate and wire into chassis rail and fit M10 bolts, spring washers and flat washers.
- 13 Tighten all bolts to torque values listed below
- 14 Mark and cut bumper as per diagram on following page.
- 15 Refit bumper as per step 4 in reverse from e) to a).
- 16 Refit tail lights and plastic trim

RECOMMENDED ASSEMBLY TORQUE LISTING

<u>Diameter</u>	<u>Grade 8.8 Bolt</u>
	<u>Nm</u>
M6	9.5
M8	21.7
M10	43.4
M12	77.3
M14	121.0
M16	189.8

TRAILBOSS

Tow bar Fitting Instructions
 To Suit LAND ROVER FREE LANDER 3-04-ON
 Part Number QTRV14
 Rating 2500Kg

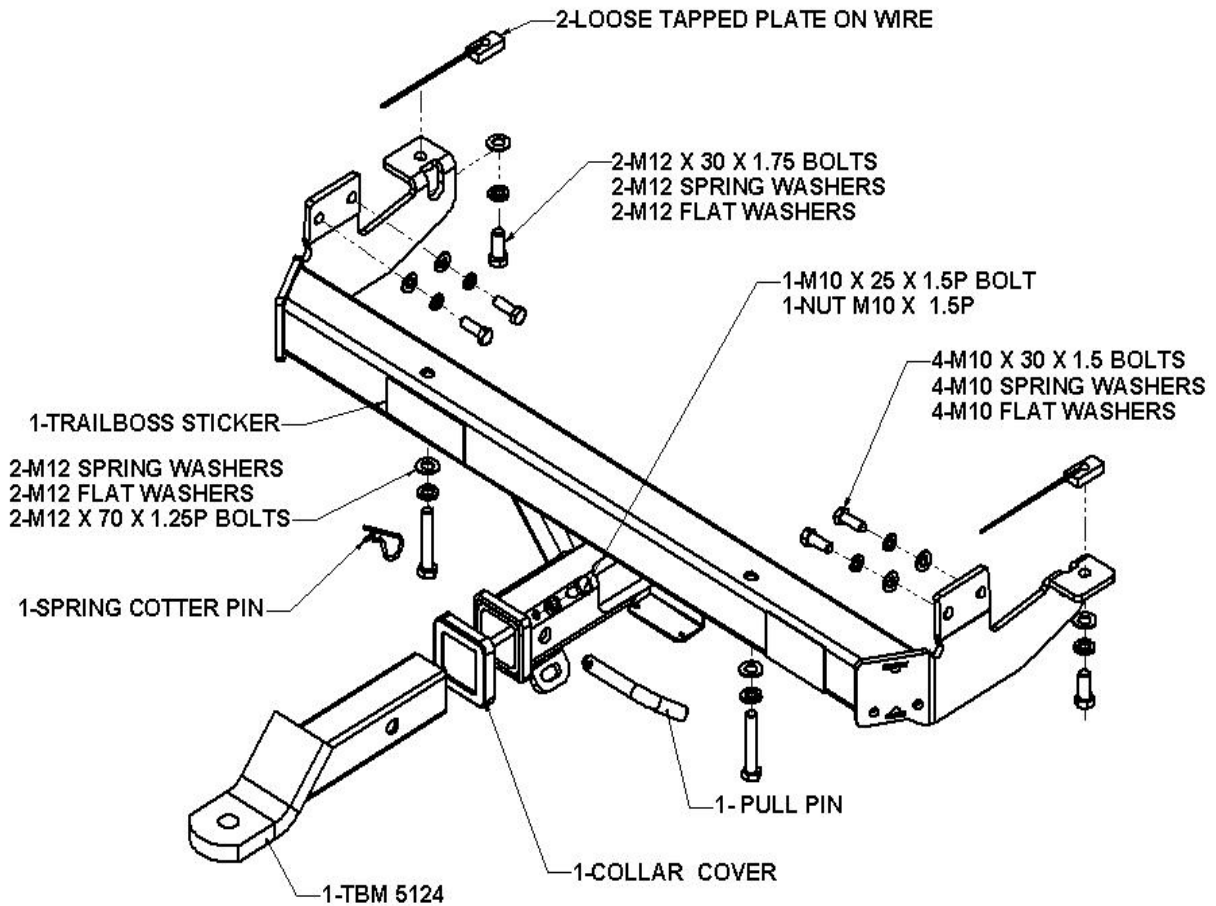

BUMPER CUT
 DIAGRAM

