



Towbar Fitting Instructions
To Suit LANDROVER DISCOVERY II 1/99-ON
Part Number QTRV9
Rating 3500Kg

1. Ensure all hardware items have been included.
2. Remove existing towbar and bumper bar. Discard existing towbar.
3. Using diagram A as guide, drill out bottom flange of chassis out to 13mm. Making sure drill is square to chassis cross member, drill top flange out to 13mm.
4. Open 13mm holes drilled in bottom flange out to 17mm to be able to fit spacer tubes.
5. Hold towbar to vehicle so as holes in side plates align with towbar mounting points on chassis side rails.
6. Fit two M16x120 bolts, spring washers and nuts semi tight.
7. Swing towbar up so as holes in towbar cross plate align with holes in chassis cross member.
8. Fit two M14x90 bolts, spring washers, flat washers to centre two holes of towbar making sure 8mm thick spacer washers are fitted in between towbar and chassis. **NOTE: Two threads per bolt only.**
9. Fit spacer tubes into 17mm holes drilled in step 4 and fit M12x110 bolts and spring washers holding bolts up in position with masking tape on same so as not to loose spacer tubes in chassis.
10. Semi tighten M14x90 bolts.
11. Fit tapped plates to top of chassis cross member to align with M12x110 bolts and semi tighten.
12. Tighten all bolts to torque listing below.
13. Refit bumper.

RECOMMENDED ASSEMBLY TORQUE LISTING

<u>Diameter</u>	<u>Grade 8.8 Bolt</u>
	<u>Nm</u>
M6	9.5
M8	21.7
M10	43.4
M12	77.3
M14	121.0
M16	189.8

TRAILBOSS

Towbar Fitting Instructions To Suit LANDROVER DISCOVERY II 1/99-ON Part Number QTRV9 Rating 3500Kg

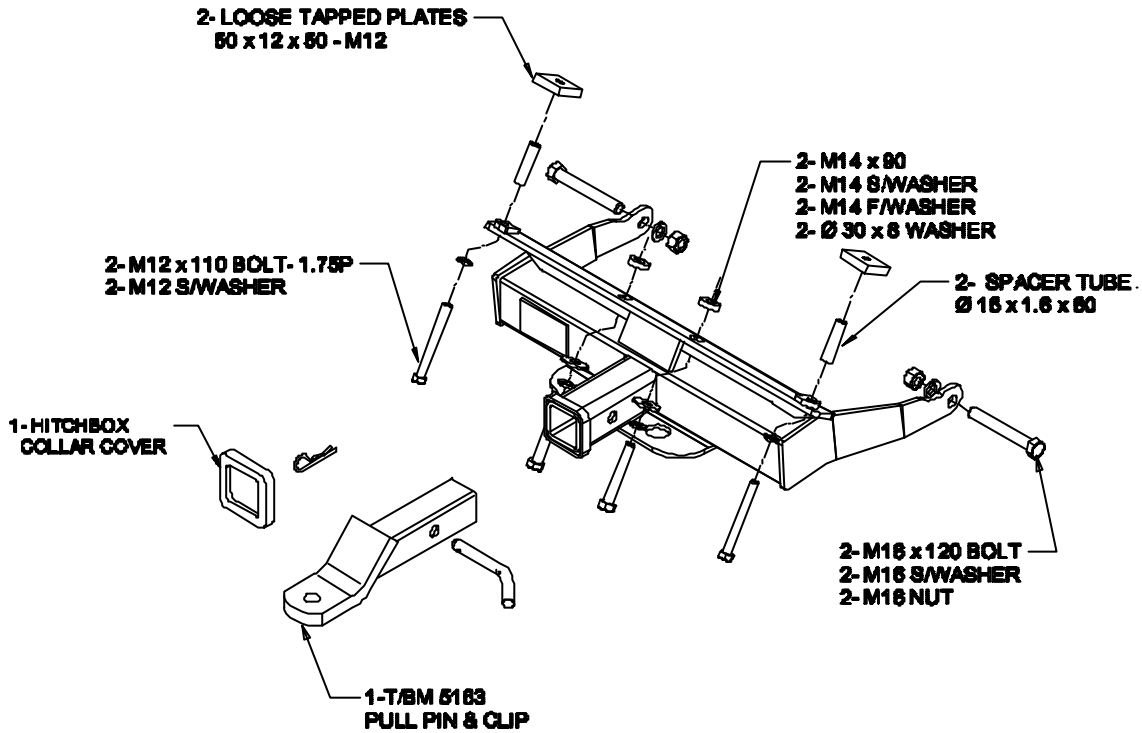

USE GUIDE HOLES TO DRILL OUT TO Ø13 & Ø17

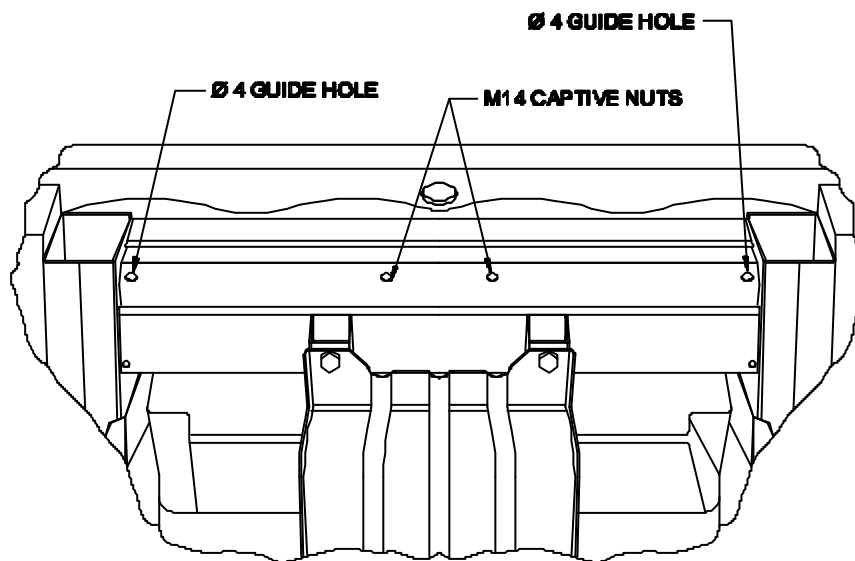

DIAGRAM 'A'