

# TRAILBOSS

## Towbar Fitting Instructions To Suit **SUBARU OUTBACK AND LIBERTY WAGON** 2010 on Part Number QTSB312L Rating 1800 kg

### **WARNING:**

1. Do not, drill, cut, weld or otherwise modify the tow bar.
2. If you are using electric welding on a motor vehicle, **always** check that the vehicle is not equipped with electronic engine or instrument management equipment. Failure to do so could **destroy** any onboard computers. If in doubt, check with the vehicle's manufacturer.

### **General:**

1. Ensure all hardware items have been included refer to assembly diagram.
2. It is recommended that the instructions are read through and completely understood before making any attempt to fit this product.
3. Be wary of any changes to vehicle designs or other accessories that may conflict with the installation of this product.
4. Before drilling ensure that the area is clear of fuel, electrical & other components.
5. All holes drilled into the body panels shall have all burrs & swarf removed then coated with a suitable rust preventative paint.
6. For vehicles that require the bumper to be cut. Ensure cut out area is in correct position on the vehicle prior to cutting the bumper.
7. The high tensile fasteners supplied with this product were used to achieve the specified rating. If replacement is required ensure that fasteners of the same rating & quality are used. Contact an authorized **Trailboss** dealer if further information is required.
8. Ensure that all hardware is fastened to torque list below check fasteners on regular basis.
9. Tow bar load rating sticker provided with this product shall be conspicuously located on inside rear end of the driver's door. **(See diagram below).**
10. Trailboss recommends that you check your tow ball to ensure that it complies with the Australian standards **AS 4177.2**.
11. **PLEASE NOTE:** It is advised to remove your lug or tbn when not actually towing so as to produce a clear view of the vehicles registration plate if obscured, and to also provide maximum available departure angle

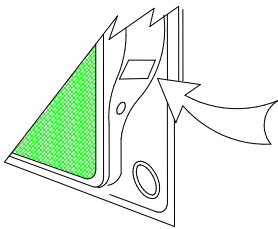

Place load rating sticker  
inside driver's door here

### **FOR TOWING PURPOSES ONLY**

For towing capacity details please refer to vehicle owner's manual or to the manufacturer. Overloading can void your warranties.

### **RECOMMENDED ASSEMBLY TORQUE LISTING**

Diameter    Grade 8.8 Bolt

M6	9.5 Nm
M8	21.7 Nm
M10	43.4 Nm
M12	77.3Nm
M14	146 Nm
M16	189.8 Nm

### **Tow bar Maintenance and Care.**

Trailboss recommends that bolt torque's, as listed below, are routinely and regularly inspected and checked for correct tension. Replace any worn or defective parts.

We recommended to remove Tow Ball Mounts (TBM's, tongues or lugs) when not being used for any considerable length of time.

So as to avoid injury, when not towing it is suggested that the tongue, Pull Pin and R-clip are removed then stored in a safe, clean and dry place, away from excessive moisture.

Hitch Pull Pins and spring "R" clips are regularly checked for proper installation. Replace any worn or defective parts.

# TRAILBOSS

Towbar Fitting Instructions  
 To Suit **SUBARU OUTBACK AND LIBERTY WAGON** 2010 on  
 Part Number QTSB312L  
 Rating 1800 kg

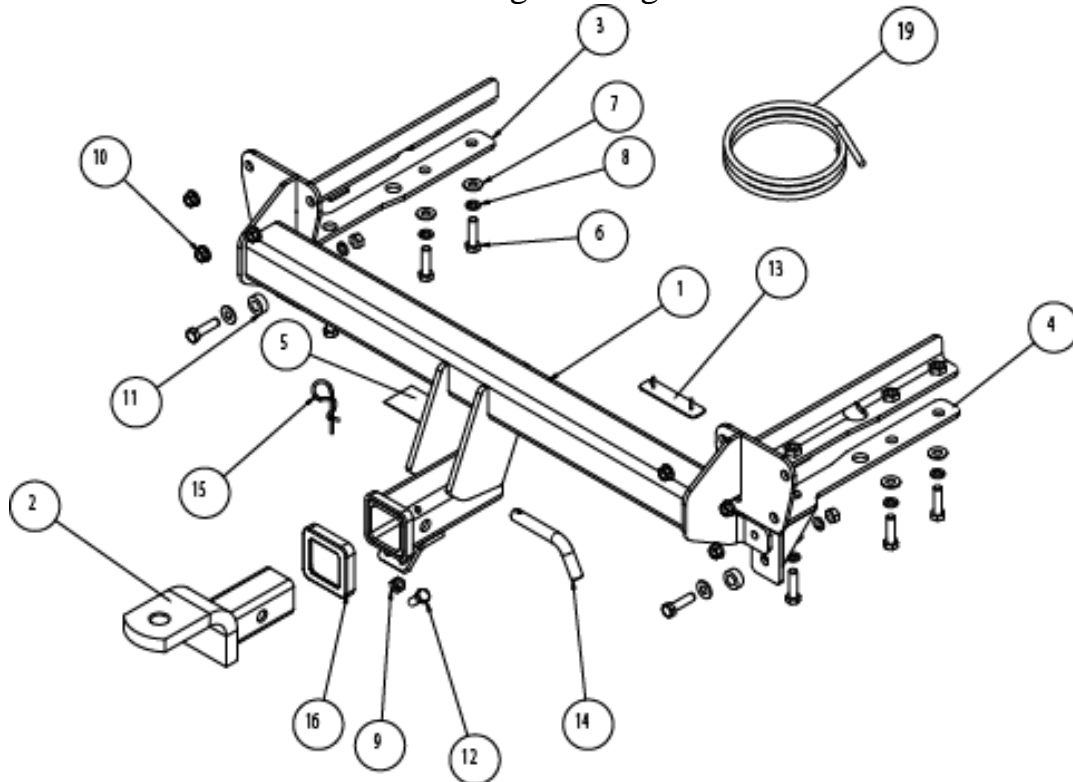

Item 17 & 18 are not shown in the layout diagram  
 Bolts used for shipment purposes should be discarded

Figure 1 – Layout Diagram

ITEM NO.	DESCRIPTION	QTY.
1	WELDED ASSY SUBARU OUTBACK & LIBERTY WAGON	1
2	T.B.MOUNT	1
3	PASSENGER SIDE BRKT ASSY	1
4	DRIVER SIDE BRKT ASSY	1
5	CP	1
6	M10 x 40 1.5P BOLT	8
7	Washer Flat M10 x 23 x 2 z/p	8
8	M10 X 3.5 X 2.2 SPRING WSHR	8
9	NUT M10 x 1.5 Z/P HX NUTS	3
10	M10 WHIZ NUT 1.25P	6
11	10mm Round 25mm dia Sacer	2
12	BOLT M10-1.50 x 25	1
13	PLUG BRACKET	1
14	PULL PIN	1
15	SPRING COTTER PIN	1
16	HITCH BOX COLLAR COVER	1
17	FITTING INSTRUCTIONS	1
18	LRL	1
19	WIRING LOOM	1



Towbar Fitting Instructions  
To Suit **SUBARU OUTBACK AND LIBERTY WAGON** 2010 on  
Part Number QTSB312L  
Rating 1800 kg

**STEPS TO FIT TOWBAR**

 Position the vehicle on to a safe working height on the hoist before commencing fitment.

1. Remove the Rear Bumper from the vehicle via the following steps:

(a) Remove scrivets x 2 to remove the rear light plastic cover.

*Note: Repeat the step for passenger side.*

(b) Remove bolts x 2 and remove the rear lights after detaching the wires.

*Note: Repeat the step for passenger side.*

(c) Remove scrivets x 5 under the bumper bar (3 in the centre and 2 on each side).

(d) Remove scrivet x 1 from the top of the wheel arch.

*Note: Repeat the step for passenger side.*

(e) Remove scrivet x 1 and and screw x 1 and remove the mud flap.

*Note: Repeat the step for passenger side.*

(f) Carefully pull the bumper out starting from the sides.

2. Remove the Impact Beam from the back panel, removing M10 nuts x 4 from each side.

3. Remove the exhaust by removing the rubber hanger mounts x 2 and the nuts x 2 holding the muffler.

*Note: Repeat the step for passenger side.*

4. Locate the towbar into the chassis rail. On the back panel, fasten with M10 whiz nuts x 3 (slotted hole to be left vacant).

5. Drill holes x 2 (25mm) in the heat shield. Repeat the step for passenger side. Refer to Figure 2.

6. Refit the heat shield.

7. Sandwich the heat shield in between the chassis rail and the lower bracing bracket and let the M10 bolts x 3, spring washers x 3 and flat washers x 3 go through the arrangement. The bolts will go through the 25mm drilled holes in the heat shield.

*Note: Repeat the step for passenger side.*

8. Tighten and torque all bolts up to the torque requirement as mentioned on page 1.

9. Cut the bumper as illustrated in Figure 3.

10. Drill the plug bracket holes, as illustrated in Figure 4.

11. Affix the load rating label, as shown in the diagram on page 1.

Towbar Fitting Instructions  
To Suit **SUBARU OUTBACK AND LIBERTY WAGON** 2010 on  
Part Number QTSB312L  
Rating 1800 kg

12. Refit the bumper in the reverse order.

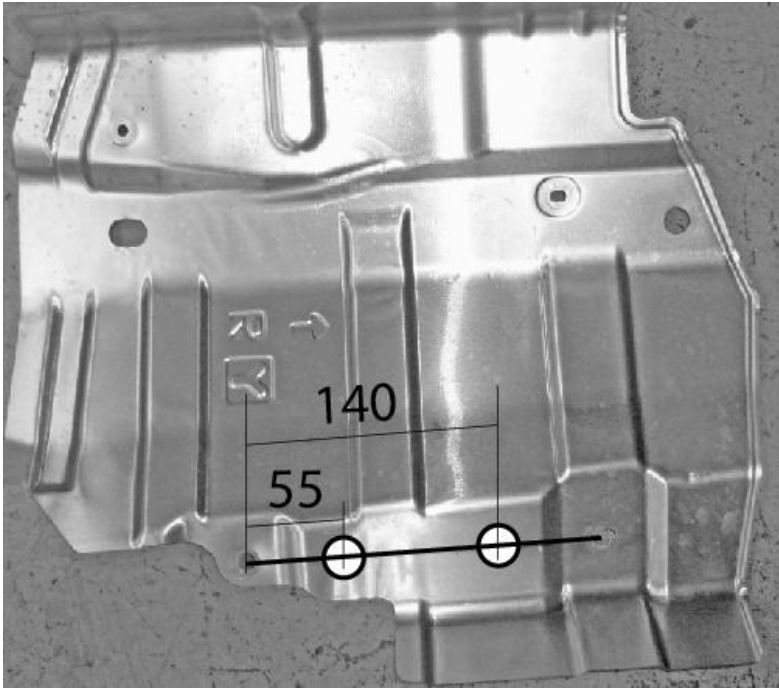

Figure 2 – Drill holes in the heat shield.

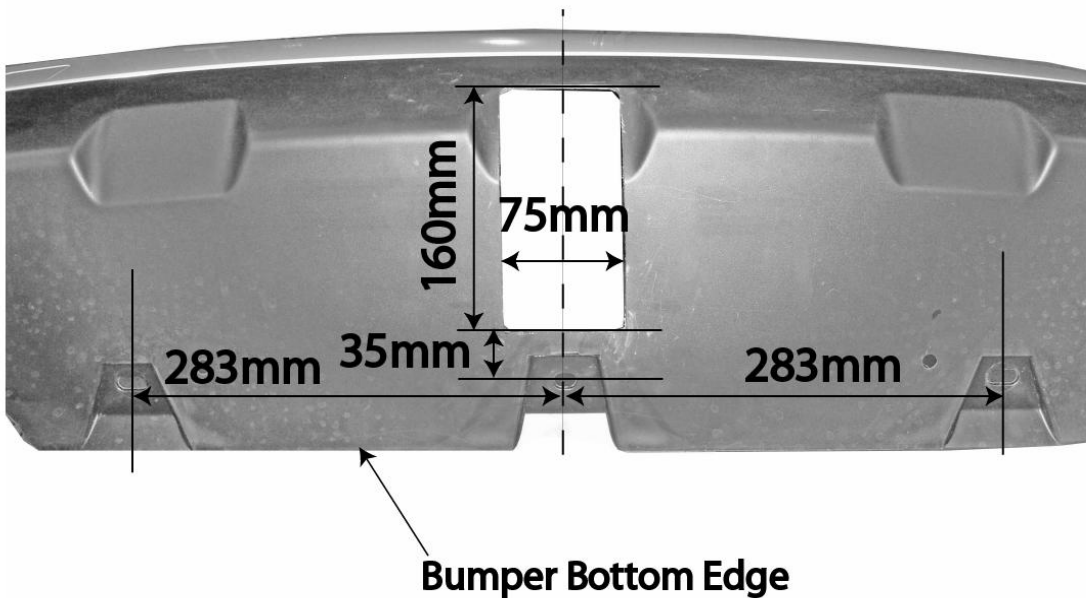

Figure 3 – Bumper Cut out Diagram.

Note – Use the same Bumper cut out measurements for Subaru Outback and Liberty Wagon.

Towbar Fitting Instructions  
To Suit **SUBARU OUTBACK AND LIBERTY WAGON** 2010 on  
Part Number QTSB312L  
Rating 1800 kg

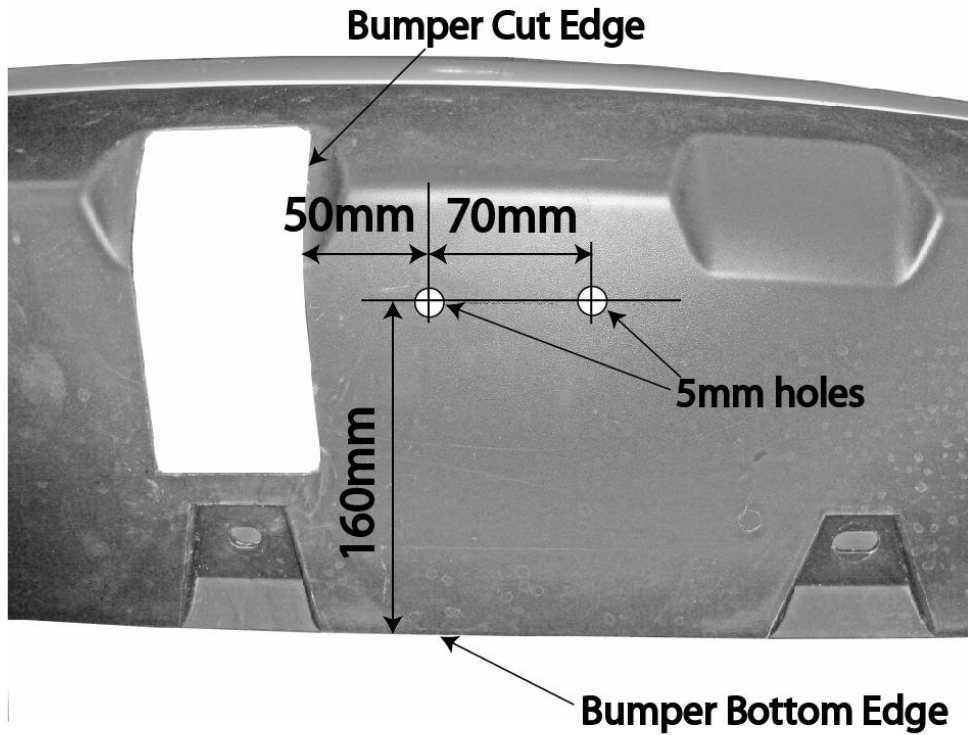

Figure 4 – Drill holes to fit plug bracket.



Wiring Loom Fitting Instructions  
To Suit Subaru Liberty/Outback MY10 Sedan & Wagon  
Part Number 100201-WL

**Wiring Loom Installation Instructions**

Subaru Liberty/Outback MY10 Sedan and Wagon  
Part No: 100201-WL

**Tail Harness Length Required:**

1200mm (Wagon)

1800mm (Sedan)

RPA Override Switch Part No: 04848 (If Fitted)

Wiring Loom Installation Time: Approx 25 Mins



Wiring Loom Fitting Instructions  
To Suit Subaru Liberty/Outback MY10 Sedan & Wagon  
Part Number 100201-WL

**The following applies to both Sedan and Wagon models:**

1. Remove all the required trims to gain access to the LHS rear quarter of the vehicle.
2. Remove the rear bumper cover.
3. On the outer LHS rear quarter of the vehicle, locate the grommet sitting in between the rear wheel arch and the vent. Remove the grommet.
4. On the outer LHS rear quarter of the car, locate and remove the grommet near the vent. Widen the grommet hole to Ø30mm using a step drill. File the grommet hole of any rough edges and spray with rust inhibitor.
5. Secure the Tail Harness (P/No: 100201-WL; 1200mm for wagon and 1800mm for sedan) socket to the towbar mounting bracket using M4 fasteners (not supplied).
6. Route the Tail Harness across the top of the towbar towards the LHS grommet.
7. Route the Tail Harness into the grommet hole. Adjust the Tail Harness grommet to the desired location ensuring that the grommet sits properly in place. Secure with cable ties (not supplied).
8. Connect the Tail Harness 10-way connector into the Trailer Patch Harness (P/no: 100201-WL) 10-way connector and route the Trailer Patch Harness towards the vehicle break out connector. In sedan models, this is located at the rear of the vehicle near the LHS of the wheel well. In wagon models, this is by the LHS wheel arch area.
9. Connect the Trailer Patch Harness to the vehicle break out connector.
10. Test the Trailer socket using a light board or multi-meter.
11. Secure the all harnesses using cables ties (not supplied).
12. Refit all removed parts and secure all fasteners.
13. Place instructions in glove box after fitment.