

TRAILBOSS

Towbar Fitting Instructions
To Suit **SUBARU XV**
Part Number **QTSB314L**
Rating **1400/140** kg

PLACE THESE INSTRUCTIONS IN THE VEHICLE'S GLOVEBOX AFTER INSTALLATION IS COMPLETE

WARNING:

1. Do not, drill, cut, weld or otherwise modify the tow bar.
2. If you are using electric welding on a motor vehicle, **always** check that the vehicle is not equipped with electronic engine or instrument management equipment. Failure to do so could **destroy** any onboard computers. If in doubt, check with the vehicle's manufacturer.
3. The high tensile fasteners supplied with this product were used to achieve the specified rating. If replacement is required ensure that fasteners of the same rating & quality are used. Contact an authorised **Trailboss** dealer if further information is required.

General:

1. Ensure all hardware items have been included refer to assembly diagram.
2. It is recommended that the instructions are read through and completely understood before making any attempt to fit this product.
3. Be wary of any changes to vehicle designs or other accessories that may conflict with the installation of this product.
4. Before drilling ensure that the area is clear of fuel, electrical & other components.
5. All holes drilled into the body panels shall have all burrs & swarf removed then coated with a suitable rust preventative paint.
6. For vehicles that require the bumper to be cut. Ensure cut out area is in correct position on the vehicle prior to cutting the bumper.
7. The high tensile fasteners supplied with this product were used to achieve the specified rating. If replacement is required ensure that fasteners of the same rating & quality are used. Contact an authorized **Trailboss** dealer if further information is required.
8. Ensure that all hardware is fastened to torque list below check fasteners on regular basis.
9. Tow bar load rating sticker provided with this product shall be conspicuously located on inside rear end of the driver's door. **(See diagram below).**
10. Trailboss recommends that you check your tow ball to ensure that it complies with the Australian standards **AS 4177.2**.
11. **PLEASE NOTE:** It is advised to remove your lug or tbm when not actually towing so as to produce a clear view of the vehicles registration plate if obscured, and to also provide maximum available departure angle

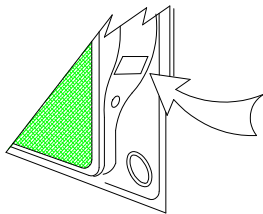

Place load rating sticker
inside driver's door here

FOR TRAILER TOWING PURPOSES ONLY
For towing capacity details please refer to vehicle owner's manual or to the manufacturer. Overloading can void your warranties.

RECOMMENDED ASSEMBLY TORQUE LISTING

Diameter	Grade 8.8 Bolt
M6	9.5 Nm
M8	21.7 Nm
M10	43.4 Nm
M12	77.3Nm
M14	146 Nm
M16	189.8 Nm

Tow bar Maintenance and Care.

Trailboss recommends that bolt torque's, as listed below, are routinely and regularly inspected and checked for correct tension. Replace any worn or defective parts.

We recommended to remove Tow Ball Mounts (TBM's, tongues or lugs) when not being used for any considerable length of time.

So as to avoid injury, when not towing it is suggested that the tongue, Pull Pin and R-clip are removed then stored in a safe, clean and dry place, away from excessive moisture.

Hitch Pull Pins and spring "R" clips are regularly checked for proper installation. Replace any worn or defective parts.

TRAILBOSS

Towbar Fitting Instructions
 To Suit **SUBARU XV**
 Part Number **QTSB314L**
 Rating **1400/140 kg**

PLACE THESE INSTRUCTIONS IN THE VEHICLE'S GLOVEBOX AFTER INSTALLATION IS COMPLETE

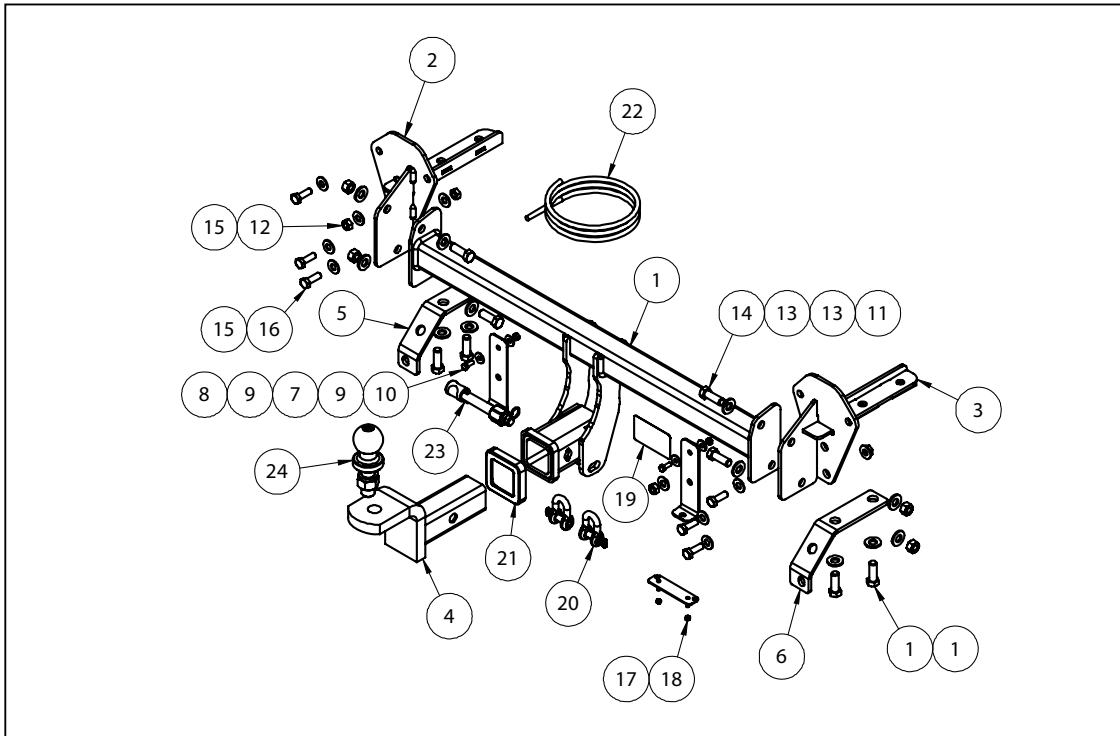

ITEM NO.	DESCRIPTION	QTY.
1	TOWBAR CENTRE SECTION ASSY	1
2	CHASSIS INSERT LHS	1
3	CHASSIS INSERT RHS	1
4	CLASS 4 TBM ASSY	1
5	SUPPORT BRACKET LHS	1
6	SUPPORT BRACKET RHS	1
7	BUMPER BRACKET	2
8	HEX NUT M6x1.0	2
9	FT WASHER 1-4 x 3-4 x 16g BRT	4
10	SET SCREW M6x16 PC8.8	2
11	HEX NUT M12x1.75 PC8	4
12	NUT HX M10-1.25 Z/P	4
13	WASHER FLAT 1/2"x1 1/8"x1/8"	12
14	SET SCREW M12x35 1.75P GR8.8	8
15	WASHER FLAT M10x23x2 Z/P	10
16	SET SCREW M-10-1.25x30 GR8.8 Z/P	6
17	PLUG BRACKET	1
18	NUT NYLOC M4-0.7 Z/P	2
19	ACRYLIC CP LABEL	1
20	10mm "D" CHACKLE	2
21	HITCH BOX COLLAR COVER	1
22	WIRING LOOM	1
23	SILENT HITCH PIN-SILVER	1
24	50mm TOWBALL	1

TRAILBOSS

Towbar Fitting Instructions
To Suit **SUBARU XV**
Part Number **QTSB314L**
Rating **1400/140** kg

PLACE THESE INSTRUCTIONS IN THE VEHICLE'S GLOVEBOX AFTER INSTALLATION IS COMPLETE

INSTRUCTION:

1. Remove 2 Plastic Scrivets and 1 Screw from inside of Rear Wheel Arc for both LH & RH side.
2. Remove 5 Screws from under side of Bumper Bar; remove Mud Flap to get gain access to the fifth Scrivet for both LH & RH side.
3. Remove 2 Screws from rear lights for both LH & RH side and then pull back firmly on lights to remove them; firmly pull on bar to remove from car.
4. Remove 3 Screws from Impact Beam for both LH & RH side and remove Impact Beam from the car and discard them.
5. Remove 2 Plastic Caps from underside of Chassis Rail and discard them.
6. Remove Plastic Bumper Bracket and discard it.
7. Insert Chassis Insert into chassis rail, loosely secure with 2 M10 Bolt and M10 Nut, and also secure new Bumper Bracket in place of the original with M6 Bolt for both LH & RH side. (see Figure 1)
8. Mount Support Bracket to Chassis Insert and rail with 2 M12 Bolts, 1 M10 Bolt and Nuts for both LH & RH side. (see Figure 2)
9. Mount Towbar to the car and secure it with 4 M12 Bolts and Nuts. (see Figure 3)
10. Tighten all fasteners to torque specifications provided.
11. In the middle of the Bumper Bar, cut out 100x80 mm as shown in the picture. (see Figure 4)
- 12. If installing wiring onto the vehicle with compatible plug to the provided plug bracket:**
Mark out and drill 2x \varnothing 5mm holes 69mm apart on bumper skin to support the plug bracket. Free bracket threads through drilled holes prior to reinstalling bumper.
13. Refit all parts to vehicle in reverse order of disassembly.



Figure 1, Insert Chassis Insert

TRAILBOSS

Towbar Fitting Instructions
To Suit **SUBARU XV**
Part Number **QTSB314L**
Rating **1400/140 kg**

PLACE THESE INSTRUCTIONS IN THE VEHICLE'S GLOVEBOX AFTER INSTALLATION IS COMPLETE



Figure 2, Mount Support Bracket



Figure 3, Mount Towbar

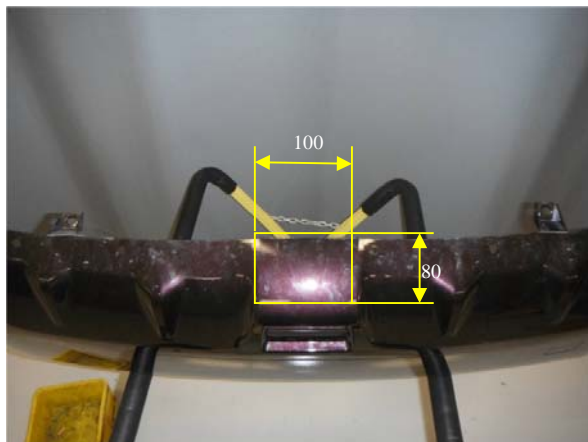

Figure 4, Bumper Cut



Wiring Loom Fitting Instructions
To Suit Subaru Liberty (Sedan & Wagon), Outback & Forester
(2003 – Onwards), Subaru XV
Part Number 100201-WL

Wiring Loom Installation Instructions

Subaru Liberty (Sedan & Wagon),
Outback & Forester, Subaru XV
Part No: 100201-WL

Tail Harness Length Required:
Liberty / Outback - 1200mm (Wagon)
Liberty – 1800mm (Sedan)
Forester – 1800mm
Subaru XV – 1200mm (WLT024)

Liberty Wagon & Outback – Page 2
Liberty Sedan – Page 3
Forester – Page 4
Subaru XV – Pages 5 - 6

Wiring Loom Installation Time: Approx. 25 Mins



Wiring Loom Fitting Instructions
To Suit Subaru Liberty (Sedan & Wagon), Outback & Forester
(2003 – Onwards), Subaru XV
Part Number 100201-WL

The following steps are for the Liberty Wagon & Outback models only. For liberty Sedan models, please proceed to page 6. For Forester models, please proceed to page 9.

1. In the luggage compartment area, remove the rear sun shade and all floor trims.
2. Remove the LHS and RHS tail lights.
3. Remove the rear bumper fascia fasteners and the rear bumper fascia.
4. Remove the rear trim.
5. Remove the rear passenger seat cushion.
6. Remove the LHS rear passenger sill trim.
7. Remove the two fasteners from the LHS rear luggage compartment trim.
8. Remove the LHS luggage compartment trim fasteners and then remove the LHS luggage compartment trim.
9. On the outer LHS rear quarter of the car, locate and remove the grommet near the vent. Widen the grommet hole to Ø30mm using a step drill.
10. File any rough or sharp edges and spray on rust inhibitor.

Note: For vehicles fitted with sunroofs, drill a Ø2mm pilot hole in the area below the sunroof drain. Drill out the hole to Ø30mm using a step drill. File any sharp or rough edges and spray on rust inhibitor.

11. Secure the Tail Harness socket (tail length 1200mm) to the towbar mounting bracket using M4 fasteners (not supplied).
12. Route the Tail Harness along the towbar and into the LHS rear quarter grommet.
13. Inside the luggage compartment LHS; retrieve the tail harness from the grommet hole ensuring that the tail harness grommet is seated correctly.
14. Locate and free the vehicle 10-way female break out connector.
15. Connect the Trailer Patch Harness (100201-WL) to the tail harness.
16. Connect the trailer patch harness to the break out connector.
17. Test the Trailer Harness function using a Light Board or multimeter.
18. Secure all Harnesses using cables ties (not supplied).
19. Re-fit all removed parts and secure all fasteners, ensuring there are no squeaks or rattles.
20. Place the instructions in glove box after fitment.



Wiring Loom Fitting Instructions
To Suit Subaru Liberty (Sedan & Wagon), Outback & Forester
(2003 – Onwards), Subaru XV
Part Number 100201-WL

The following steps are for Liberty Sedan models only. For Forester models, please proceed to page 9. For Liberty Wagon & Outback models, please refer to page 2.

1. Remove the rear bumper from the vehicle.
2. Remove the luggage compartment floor carpet.
3. Remove the rear trim by first removing the indicated fasteners.
4. Remove the LHS luggage compartment trim by first removing the two fasteners.
5. On the outer LHS rear quarter of the car, locate and remove the grommet near the vent (in between the rear wheel arch and the vent). Widen the grommet hole to Ø30mm using a step drill. File the grommet hole of any rough or sharp edges and spray on rust inhibitor.

Note: For vehicles fitted with sunroofs, drill a Ø2mm pilot hole in the area below the sunroof drain. Drill out the hole to Ø30mm using a step drill. File any sharp or rough edges and spray on rust inhibitor.

6. Secure the Tail Harness socket (tail length 1800mm) to the towbar mounting bracket using M4 fasteners (not supplied).
7. Route the Tail Harness along the towbar and into the LHS rear quarter grommet.
8. Slide the Tail Harness grommet into the desired position, ensuring that it is seated correctly into the vehicle grommet hole. Secure with a cable tie (not supplied).
9. Connect the Tail Harness 10-way connector into the Trailer Patch Harness (P/no: 100201-WL) 10-way mating connector.
10. Route the Trailer Patch Harness towards the vehicle break out connector, located at the rear of the vehicle near the LHS of the wheel well.
11. Connect the Trailer Patch Harness to the vehicle break out connector.
12. Re-fit the rear bumper fascia.
13. Secure all harnesses to the vehicle using cable ties (not supplied).
14. Test the Trailer Harness function using a trailer light board or multimeter.
15. Re-fit all removed parts and secure all fasteners.
16. Place the instructions in the glove box after fitment.



Wiring Loom Fitting Instructions
To Suit Subaru Liberty (Sedan & Wagon), Outback & Forester
(2003 – Onwards), Subaru XV
Part Number 100201-WL

The following steps are for Forester models only. For Liberty models, please refer to page 6. For Liberty Wagon & Outback models, please refer to page 2.

1. In the LHS of the luggage compartment, remove the tool tray by first removing the two clips.
2. On the outer LHS rear quarter of the car, locate and remove the grommet near the vent. Widen the grommet hole to Ø30mm using a step drill.
3. File any rough or sharp edges and spray on rust inhibitor.

Note: For vehicles fitted with sunroofs, drill an Ø2mm pilot hole in the area below the sunroof drain. Drill out the hole to Ø30mm using a step drill. File any rough or sharp edges and spray on rust inhibitor.

4. Secure the Tail Harness socket (tail length 1200mm) to the towbar mounting bracket using M4 fasteners (not supplied).
5. Route the Tail Harness along the towbar and into the LHS rear quarter grommet.
6. Inside the LHS of the luggage compartment, retrieve the tail harness from the grommet hole ensuring that the tail harness grommet is seated correctly.
7. Locate and free the vehicle 10-way female break out connector.
8. Connect the Trailer Patch Harness (100201-WL) to the tail harness.
9. Connect the trailer patch harness to the break out connector.
10. Test the Trailer Harness function using a Light Board or multimeter.
11. Secure all Harnesses using cables ties (not supplied).
12. Re-fit all removed parts and secure all fasteners, ensuring there are no squeaks or rattles.
13. Place the instructions in glove box after fitment.

Wiring Loom Fitting Instructions
To Suit Subaru Liberty (Sedan & Wagon), Outback & Forester
(2003 – Onwards), Subaru XV
Part Number 100201-WL

The following steps are for Subaru XV models only. For Liberty Wagon & Outback models, please refer to page 2. For Liberty Sedan models, please refer to page 6. For Forester models, please refer to page 9.

1. In the luggage compartment, remove the floor carpet cover and the parcel shelf.
2. Remove the two luggage compartment storage trays by first removing the clips.
3. Remove the rear luggage compartment trim by first removing the two clips and pulling in an upwards direction.
4. Remove the LHS upper 'C' pillar trim by releasing the one screw.
5. Dislodge the LHS luggage compartment trim by removing the two screws.
6. On the LHS rear quarter panel, connect the trailer harness (100201-WL) connector to the vehicle break out connector.
7. To enable the RPA cutout, splice to the loose GREY/BLACK wire onto Pin 1 of the connector (1).
8. On the tail harness splice the GREY wire (2) back into the white ground wire of the harness (3).

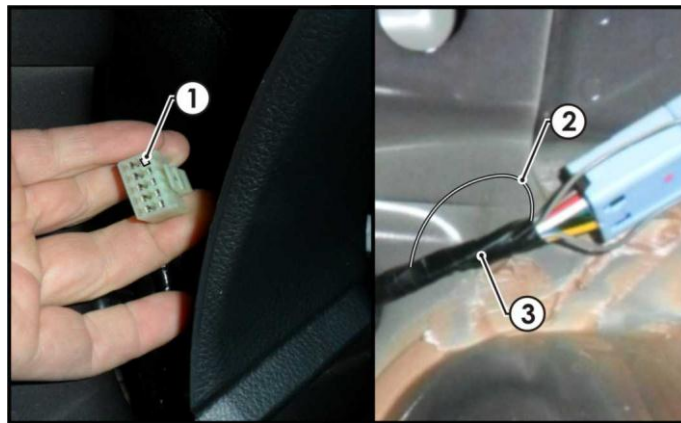

TRAILBOSS

Wiring Loom Fitting Instructions To Suit Subaru Liberty (Sedan & Wagon), Outback & Forester (2003 – Onwards), Subaru XV Part Number 100201-WL

9. Route the trailer harness (1) along the rear luggage compartment, towards the existing vehicle grommet (2) as shown.

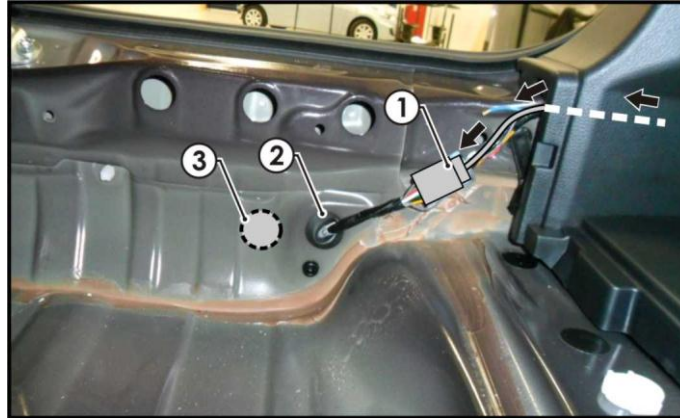

Note: If vehicle grommet is occupied as sunroof drainage, drill a Ø30mm hole (3) in the location shown.

10. Mount the trailer socket to the tow bar mounting bracket using M4 fasteners (not supplied).
11. Route the tail harness across the tow bar towards the RHS of the vehicle and up through the previously drilled out hole.
12. Ensure the tail harness grommet is seated correctly and secure in place using a cable tie (not supplied).
13. Connect the tail harness (tail length 1200mm) 8-way connector to the trailer patch mating 8-way connector.
14. Test the trailer patch function using a light board or multi meter.
15. Secure all harnesses using cable ties (not supplied).
16. Re-fit all removed parts and secure all fasteners, ensuring there are no squeaks or rattles.
17. Place the fitting instructions in the glove box after fitment.



FITTING INSTRUCTIONS

Silent Anti-Rattle Hitch Pin (PR0001)

• These fitting instructions are supplied to ensure understanding of how the HITCH PIN should be fitted and used correctly.

• Once installed, we recommend **ALL** instructions are kept and placed in the vehicle glove box.

NOTE: Routine maintenance and inspection of the towbar & HITCH PIN is required. Regularly inspect for wear and check the tightness of the Hitch Pin. Follow instructions below to retighten the nut when necessary.

***Do not tow with your vehicle if the R CLIP or the HITCH PIN is loose or missing. Replacement parts are available from your Pro Series Distributor.**

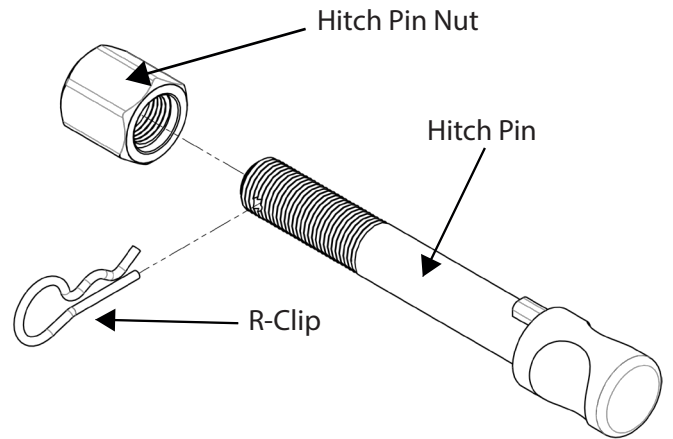

Fig 1. Silent Anti-Rattle Hitch Pin assembly

STEP 1

Insert Trailer Ball Mount (TBM) into towbar HITCHBOX, aligning hole in TBM SHANK with hole in HITCHBOX (Fig 2).

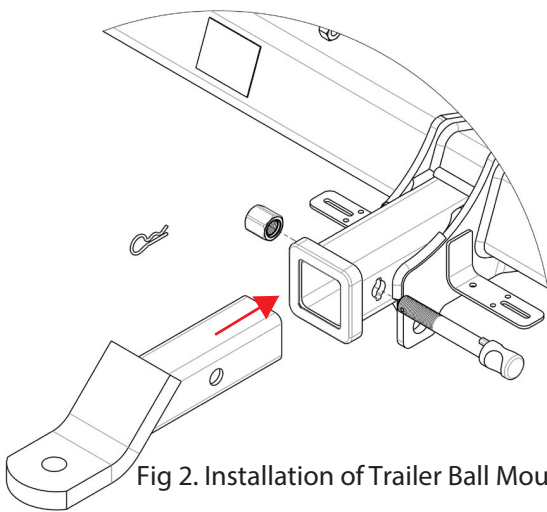

Fig 2. Installation of Trailer Ball Mount

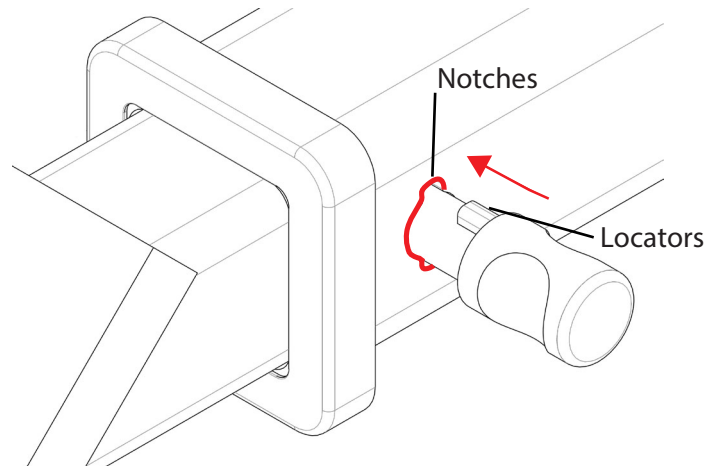

Fig 3. Silent Anti-Rattle Hitch Pin orientation

STEP 2

Insert HITCH PIN through hole in HITCHBOX and hole in TBM SHANK; ensure the LOCATORS are inserted into the NOTCHES in the HITCHBOX (Fig. 3).

STEP 3

Screw HITCH PIN NUT onto HITCH PIN ; tighten HITCH PIN NUT until finger tight, ensuring TBM is restrained from movement.

STEP 4

Tighten HITCH PIN NUT by turning nut a further 1/8th of a turn in the clockwise direction using a 24mm spanner (Fig. 4).

STEP 5

Install HITCH PIN R CLIP through the hole on the HITCH PIN (Fig. 1).

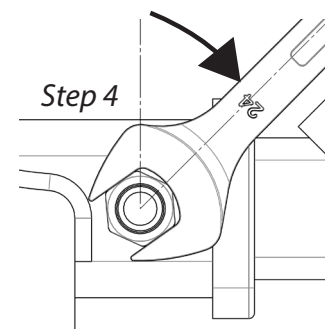

Fig 4. Tightening of Silent Anti-Rattle Hitch Pin Nut