

TRAILBOSS

Towbar Fitting Instructions
To Suit Suzuki Grand Vitara 3 Door 9-05-on
Part Number QTSU30L
Rating 1600 kg Braked
Rating 550 kg Unbraked
Max Towball down load 130 kg

WARNING:

1. Do not, drill, cut, weld or otherwise modify the tow bar.
2. If you are using electric welding on a motor vehicle, **always** check that the vehicle is not equipped with electronic engine or instrument management equipment. Failure to do so could **destroy** any onboard computers. If in doubt, check with the vehicle's manufacturer.

- 1 Ensure all hardware items have been included
- 2 Remove rear muffler from its two rubber hangers.
- 3 Remove tow hook from driver side sub frame then discard.
- 4 Lift tow bar into position then align slots in side plates with captive nuts in the sub frame then fasten with hardware supplied as per diagram on the next page.
- 5 Tighten all bolts to torque listing below.
- 6 Tow bar rating sticker to be conspicuously located on the inside of the drivers door (See diagram below).

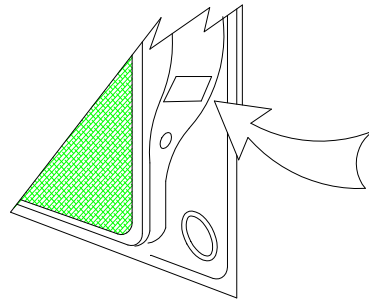

**Place load rating
sticker inside driver's
door here**

RECOMMENDED ASSEMBLY TORQUE LISTING

DiameterGrade 8.8 Bolt

	Nm;
M6	9.5
M8	21.7
M10	43.4
M12	77.3
M16	189.8

FOR TOWING PURPOSES ONLY
For towing capacity details please refer
to vehicle owner's manual or to the
manufacturer. Overloading can void
your warranties.

TRAILBOSS

Towbar Fitting Instructions
To Suit Suzuki Grand Vitara 3 Door 9-05-on
Part Number QTSU30L
Rating 1600 kg Braked
Rating 550 kg Unbraked
Max Towball down load 130 kg

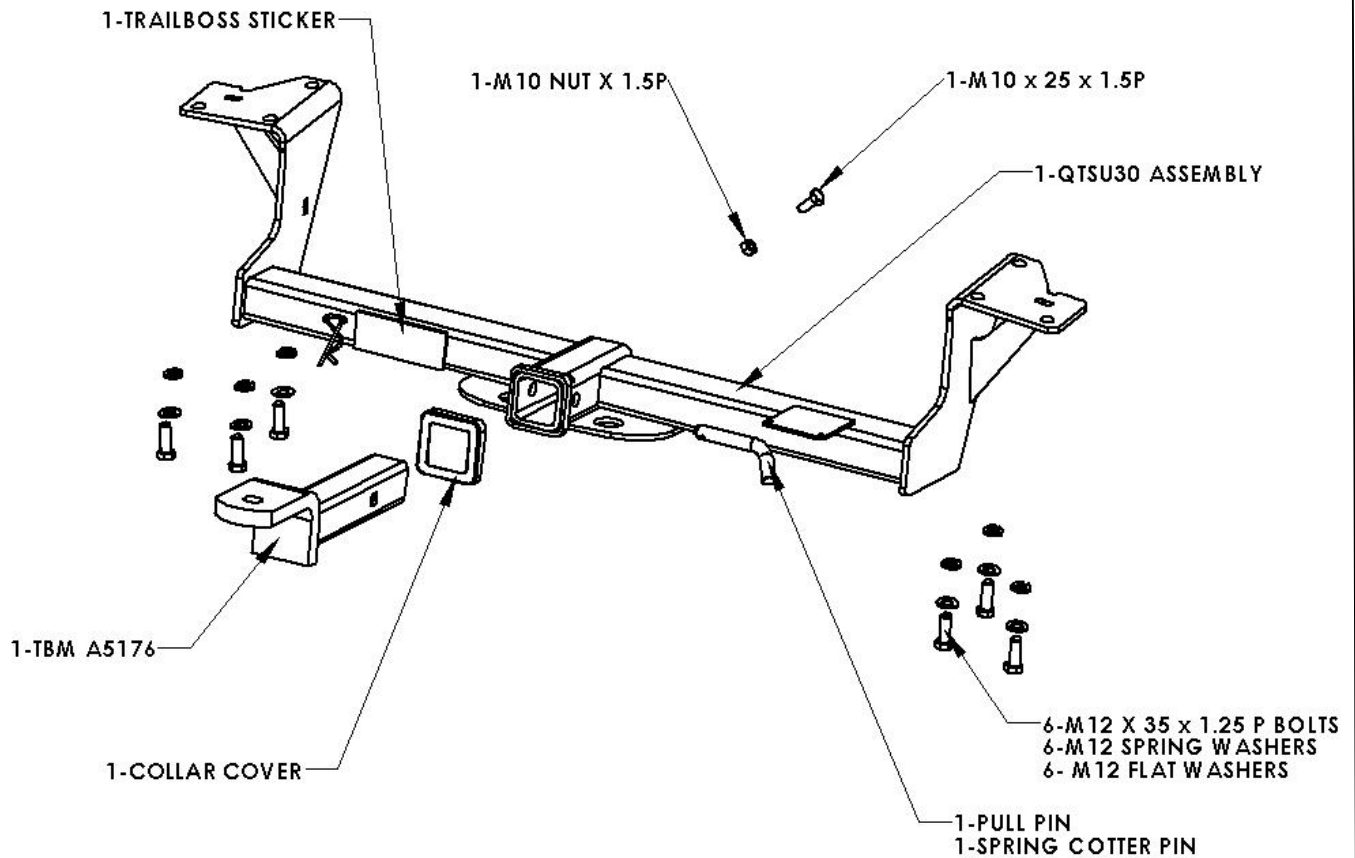

Rev:B

THE WORKHORSE OF AUSTRALIA'S TOWBARS

27-5-2015



Wiring Loom Fitting Instructions
To Suit Suzuki Grand Vitara MY12
Part Number 100712-WL

Wiring Loom Installation Instructions

**Suzuki Grand Vitara MY12
Part No: 100712-WL**

Tail Harness Length Required: 1200mm

Wiring Loom Installation Time: Approx 45 Mins

Wiring Loom Fitting Instructions To Suit Suzuki Grand Vitara MY12 Part Number 100712-WL

1. Inside the luggage compartment, remove the parcel shelf and the floor carpet cover.
2. Remove the rear luggage compartment trim by pulling in an upwards direction.
3. Remove the LHS luggage compartment seat belt fastener and luggage trim clip.
4. Remove the tool access panel and jack.
5. Carefully peel open the LHS luggage trim and disconnect the 12 volt connector.
6. On the RHS luggage compartment trim, remove the seatbelt fastener and the trim clip.
7. On the rear RHS quarter of the luggage compartment area, drill a Ø30mm hole (1) into the sheet metal in the area as shown. File hole and spray on rust inhibitor after drilling.

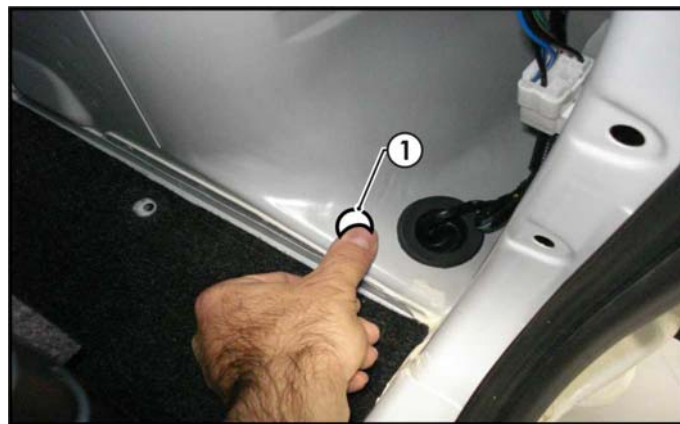

8. On the LHS of the luggage compartment, disconnect the tail light connector and connect the trailer patch (100712-WL) connectors in between.
9. Route the trailer harness along the rear of the luggage compartment towards the RHS of the vehicle.
10. On the LHS of the luggage compartment, disconnect the tail light connector and connect the trailer patch connectors in between.
11. Mount the trailer socket to the tow bar mounting bracket using M4 fasteners (not supplied).
12. Route the tail harness across the tow bar towards the RHS of the vehicle and up through the previously drilled out hole.
13. Ensure the tail harness grommet is seated correctly and secure in place using a cable tie (not supplied).



Wiring Loom Fitting Instructions
To Suit Suzuki Grand Vitara MY12
Part Number 100712-WL

14. Connect the tail harness (tail length 1200mm) 8-way connector to the trailer patch mating 8-way connector.
15. Test the trailer patch function using a light board or multi meter.
16. Secure all harnesses using cable ties (not supplied).
17. Re-fit all removed parts and secure all fasteners, ensuring there are no squeaks or rattles.
18. Place the fitting instructions in the glove box after fitment.



FITTING INSTRUCTIONS

Silent Anti-Rattle Hitch Pin (PR0001)

• These fitting instructions are supplied to ensure understanding of how the HITCH PIN should be fitted and used correctly.

• Once installed, we recommend **ALL** instructions are kept and placed in the vehicle glove box.

NOTE: Routine maintenance and inspection of the towbar & HITCH PIN is required. Regularly inspect for wear and check the tightness of the Hitch Pin. Follow instructions below to retighten the nut when necessary.

***Do not tow with your vehicle if the R CLIP or the HITCH PIN is loose or missing. Replacement parts are available from your Pro Series Distributor.**

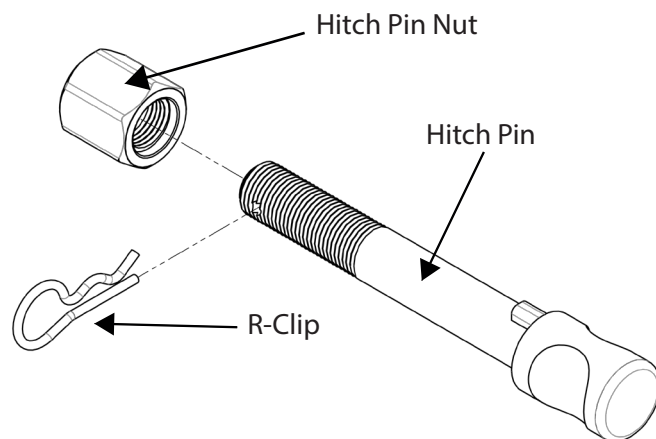

Fig 1. Silent Anti-Rattle Hitch Pin assembly

STEP 1

Insert Trailer Ball Mount (TBM) into towbar HITCHBOX, aligning hole in TBM SHANK with hole in HITCHBOX (Fig 2).

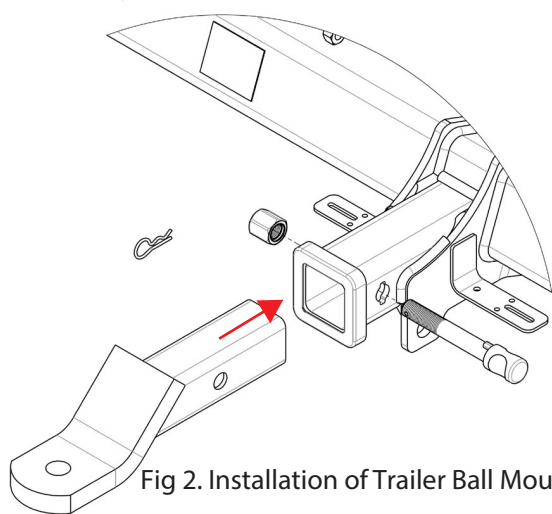

Fig 2. Installation of Trailer Ball Mount

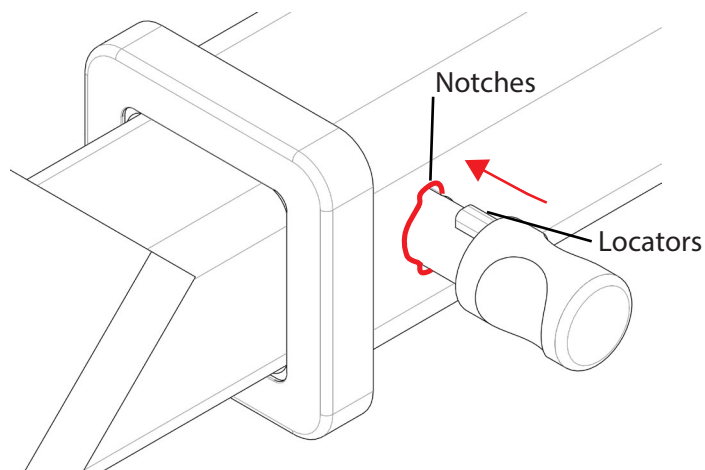

Fig 3. Silent Anti-Rattle Hitch Pin orientation

STEP 2

Insert HITCH PIN through hole in HITCHBOX and hole in TBM SHANK; ensure the LOCATORS are inserted into the NOTCHES in the HITCHBOX (Fig. 3).

STEP 3

Screw HITCH PIN NUT onto HITCH PIN ; tighten HITCH PIN NUT until finger tight, ensuring TBM is restrained from movement.

STEP 4

Tighten HITCH PIN NUT by turning nut a further 1/8th of a turn in the clockwise direction using a 24mm spanner (Fig. 4).

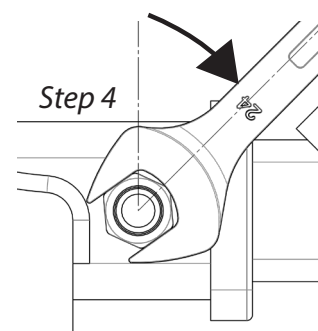

Fig 4. Tightening of Silent Anti-Rattle Hitch Pin Nut

STEP 5

Install HITCH PIN R CLIP through the hole on the HITCH PIN (Fig. 1).