

TRAILBOSS

Towbar Fitting Instructions To Suit **SUZUKI VITARA LY SERIES** Part Number **QTSU31L** Rating **1200/120 kg**

PLACE THESE INSTRUCTIONS IN THE VEHICLE'S GLOVEBOX AFTER INSTALLATION IS COMPLETED

WARNING:

1. Do not, drill, cut, weld or otherwise modify the tow bar.
2. If you are using electric welding on a motor vehicle, **always** check that the vehicle is not equipped with electronic engine or instrument management equipment. Failure to do so could **destroy** any onboard computers. If in doubt, check with the vehicle's manufacturer.
3. The high tensile fasteners supplied with this product were used to achieve the specified rating. If replacement is required ensure that fasteners of the same rating & quality are used. Contact an authorised **Trailboss** dealer if further information is required.
4. If TBM is used in inverted position tow ball may make contact with rear tailgate when lowered, which could cause damage.

General:

1. Ensure all hardware items have been included refer to assembly diagram.
2. It is recommended that the instructions are read through and completely understood before making any attempt to fit this product.
3. Be wary of any changes to vehicle designs or other accessories that may conflict with the installation of this product.
4. Before drilling ensure that the area is clear of fuel, electrical & other components.
5. All holes drilled into the body panels shall have all burrs & swarf removed then coated with a suitable rust preventative paint.
6. For vehicles that require the bumper to be cut. Ensure cut out area is in correct position on the vehicle prior to cutting the bumper.
7. The high tensile fasteners supplied with this product were used to achieve the specified rating. If replacement is required ensure that fasteners of the same rating & quality are used. Contact an authorized **Trailboss** dealer if further information is required.
8. Ensure that all hardware is fastened to torque list below check fasteners on regular basis.
9. Tow bar load rating sticker provided with this product shall be conspicuously located on inside rear end of the driver's door. **(See diagram below).**
10. Trailboss recommends that you check your tow ball to ensure that it complies with the Australian standards **AS 4177.2**.
11. **PLEASE NOTE:** It is advised to remove your lug or tbm when not actually towing so as to produce a clear view of the vehicles registration plate if obscured, and to also provide maximum available departure angle
12. Pull Pin must be fit in down position.

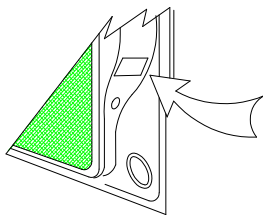

Place load rating sticker
inside driver's door here

FOR TRAILER TOWING PURPOSES ONLY
For towing capacity details please refer to vehicle owner's manual or to the manufacturer. Overloading can void your warranties.

RECOMMENDED ASSEMBLY TORQUE LISTING

Diameter	Grade 8.8 Bolt
M6	9.5 Nm
M8	21.7 Nm
M10	43.4 Nm
M12	77.3Nm
M14	146 Nm
M16	189.8 Nm

Tow bar Maintenance and Care.

Trailboss recommends that bolt torque's, as listed below, are routinely and regularly inspected and checked for correct tension. Replace any worn or defective parts.

We recommended to remove Tow Ball Mounts (TBM's, tongues or lugs) when not being used for any considerable length of time.

So as to avoid injury, when not towing it is suggested that the tongue, Pull Pin and R-clip are removed then stored in a safe, clean and dry place, away from excessive moisture.

Hitch Pull Pins and spring "R" clips are regularly checked for proper installation. Replace any worn or defective parts.

TRAILBOSS

Towbar Fitting Instructions
 To Suit **SUZUKI VITARA LY SERIES**
 Part Number **QTSU31L**
 Rating **1200/120 kg**

PLACE THESE INSTRUCTIONS IN THE VEHICLE'S GLOVEBOX AFTER INSTALLATION IS COMPLETED

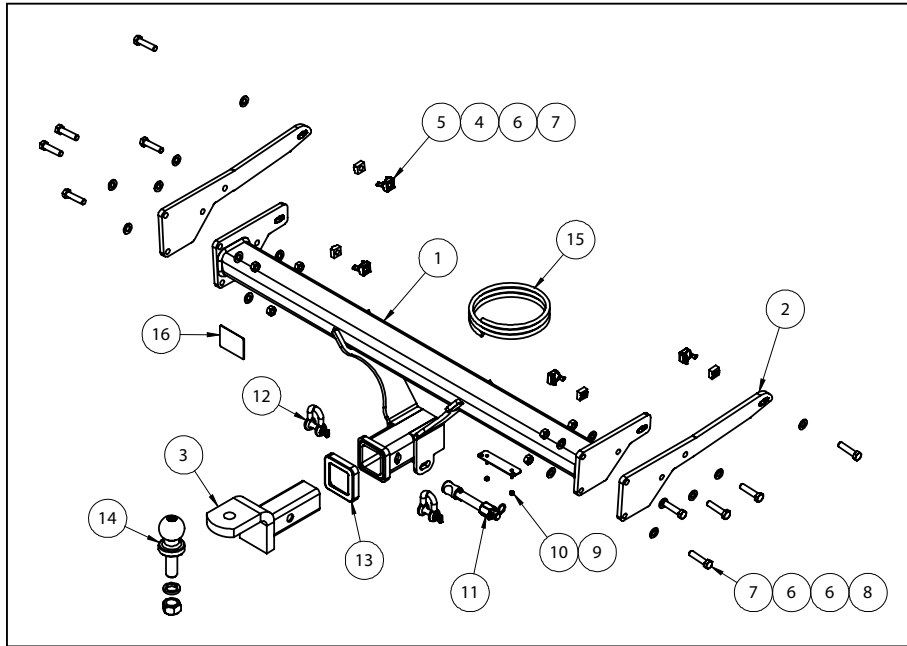

QTY.	DESCRIPTION	ITEM NO.
1	WELDED ASSEMBLY	1
2	SIDE ARM	2
1	TRAILER BALL MOUNT 21148	3
4	CAGE NUT M10x1.5	4
4	CAGE NUT RETAINER	5
16	FLAT WASHER M10 x 21 x 1.6mm	6
10	SET SCREW HEX HD M10 X 45 X 1	7
6	HEX NUT M10x1.5	8
1	PLUG BRACKET	9
2	NUT NYLOC M4-0.7 Z/P	10
1	SILENT HITCH PIN - SILVER	11
2	10mm "D" SHACKLE	12
1	HITCH BOX COLLAR COVER	13
1	50MM TOWBALL	14
1	SUZUKI VITARA LT MY15 TRAILER PATCH	15
1	ACRYLIC COMPLIANCE PLATE	16



Towbar Fitting Instructions
To Suit **SUZUKI VITARA LY SERIES**
Part Number **QTSU31L**
Rating **1200/120 kg**

PLACE THESE INSTRUCTIONS IN THE VEHICLE'S GLOVEBOX AFTER INSTALLATION IS COMPLETED

INSTRUCTION:

1. Release the rear tailgate to expose cabin space.
2. Remove 4 x Screws. Two securing the tail light and an additional two securing the bumper. Repeat for opposite side.
3. Carefully remove & disconnect tail light. Keep in a safe place for re-attachment. Repeat for opposite side.
4. On the inside of the wheel guard liner remove 1 x Push Rivet. Repeat for opposite side.
5. On the underside of the bumper where the guard liner meets the lower edge. Remove 1 x Push Rivet.
Then on the bumper edge remove 1 x Push Rivet and 1 x Screw. Repeat for opposite side.
6. Carefully detach the guard moulding to reveal the 1 x Screw and 1 x Push Rivet. Remove both and repeat for opposite side.
7. Carefully remove the bumper by peeling away at the edges. Keep in a safe place for re-attachment. Disconnect any factory fitted parking sensors.
8. Detach impact beam by removing 8 x Hex Nuts (4 Per Side). Discard impact beam.
9. Install cage nuts into respective profiles in side arm. Insert sidearm into chassis rail and loosely secure using 1 x M10 x 45 x 1.5P Set Screw and accompanying washer. Repeat for opposite side.
10. Install cage nut onto respective side flange on the centre section of the towbar. Attach centre section with aligning holes on fitted side arms. Loosely secure centre section using 6 x M10 x 45 Set Screws, Flat Washers and Nuts. Secure towbar to the chassis by securing the second M10 x 45 x 1.75P Set Screws and Washer. Repeat for opposite side.

Torque all fasteners to the specification listed below:
M10x1.5P G8.8: 44Nm
11. On bottom edge of the bumper locate the centre vertical. Cut approximately 100mm wide and 75mm up from the edge as measured from outside face of bumper.
12. Mark out and drill 2x \varnothing 5mm holes 69mm apart on bumper skin to support plug bracket. Feed bracket threads through drilled holes prior to reinstalling bumper.
13. Re-attach bumper by following steps 1-7 in reverse.



Wiring Loom Fitting Instructions
To Suit Suzuki Vitara LY
Part Number 101374-WL

Wiring Loom Installation Instructions

Suzuki Vitara LY

Part No: 101374-WL

Tail Harness Length Required: 1200mm
Power Harness: 04848 (if fitted)

Wiring Loom Installation Time: Approx 30 Mins

Important



Due to possible vehicle variations, always confirm any noted vehicle colour wires with a multi-meter to ensure the correct function is identified before soldering or scotch locking. For vehicle wires denoted with two colours (example: RED/GREEN) the first colour will always be the main wire colour while the second colour is the thinner trace colour on the wire.

Wiring Loom Fitting Instructions To Suit Suzuki Vitara LY Part Number 101374-WL

1. In the luggage compartment, remove the rear shade, floor carpet and the rear trim.
2. Remove the required fasteners on both LHS and RHS luggage compartment trims (4) to gain access to the tail light connectors.
3. Underneath the vehicle at the LHS rear quarter exterior, drill a Ø30mm hole (1) into the vehicle sheet metal. **Confirm there are no obstructions on the other side prior to drilling.**
4. Apply rust inhibitor (not supplied) after drilling.

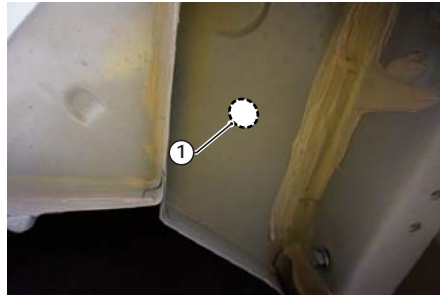

5. Disconnect the vehicle tail light connectors and connect the trailer patch (P/No: 101374-WL) connectors in between.

If the vehicle is fitted with an RPA kit, go to Step 6. Otherwise, go to Step 7.

6. For RPA over-ride, locate and disconnect the vehicle RPA Harness 1-way connector WHITE wire. Cut the WHITE wire and solder the RPA Over-ride switch wires to the WHITE wire as per the 04848 instructions. Tape back the unused 1-way connector.
7. In the LHS rear quarter area, find a suitable location on the vehicle sheet metal to secure the trailer patch ground ring terminal using a tek screw (not supplied).
8. In the LHS rear quarter area, locate the roof harness connector and following the table below, connect the ezy-tap to the corresponding vehicle wire, then connect the trailer patch terminal to the ezy-tap.

Function	Trailer Patch	Vehicle Connector
REV	BLACK	RED

9. Route the trailer patch across to the RHS tail light assembly area.
10. Disconnect the RHS vehicle tail light connectors and connect the trailer patch (P/No: 101374-WL) connectors in between.
11. At the rear exterior of the vehicle, mount the tail harness socket (1) to the towbar mounting bracket using M4 fasteners (not supplied).
12. Route the tail harness (tail length: 1200mm) across the LHS and up into the drilled out hole. Adjust the trailer patch harness grommet so that it is seated correctly and cable tie (not supplied) in place.
13. Reconnect the tail lights.
14. Test the trailer wiring harness function using a light board or multi-meter.



Wiring Loom Fitting Instructions
To Suit Suzuki Vitara LY
Part Number 101374-WL

15. Secure all harnesses using cables ties (not supplied).
16. Re-fit all removed parts and secure all fasteners, ensuring there are no squeaks or rattles.
17. Place the instructions in the glove box after fitment.



FITTING INSTRUCTIONS

Silent Anti-Rattle Hitch Pin (PR0001)

• These fitting instructions are supplied to ensure understanding of how the HITCH PIN should be fitted and used correctly.

• Once installed, we recommend **ALL** instructions are kept and placed in the vehicle glove box.

NOTE: Routine maintenance and inspection of the towbar & HITCH PIN is required. Regularly inspect for wear and check the tightness of the Hitch Pin. Follow instructions below to retighten the nut when necessary.

***Do not tow with your vehicle if the R CLIP or the HITCH PIN is loose or missing. Replacement parts are available from your Pro Series Distributor.**

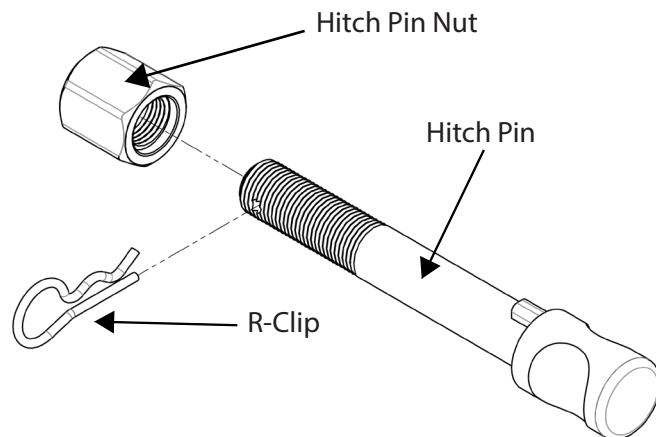

Fig 1. Silent Anti-Rattle Hitch Pin assembly

STEP 1

Insert Trailer Ball Mount (TBM) into towbar HITCHBOX, aligning hole in TBM SHANK with hole in HITCHBOX (Fig 2).

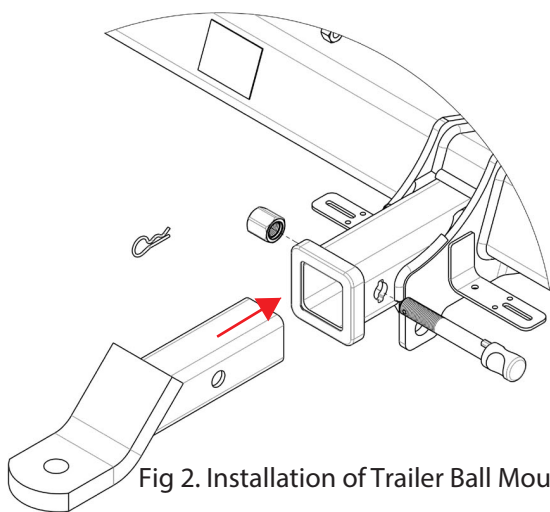

Fig 2. Installation of Trailer Ball Mount

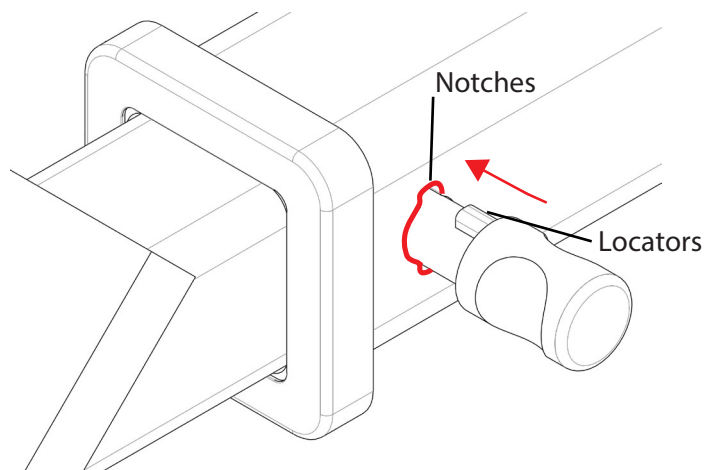

Fig 3. Silent Anti-Rattle Hitch Pin orientation

STEP 2

Insert HITCH PIN through hole in HITCHBOX and hole in TBM SHANK; ensure the LOCATORS are inserted into the NOTCHES in the HITCHBOX (Fig. 3).

STEP 3

Screw HITCH PIN NUT onto HITCH PIN ; tighten HITCH PIN NUT until finger tight, ensuring TBM is restrained from movement.

STEP 4

Tighten HITCH PIN NUT by turning nut a further 1/8th of a turn in the clockwise direction using a 24mm spanner (Fig. 4).

STEP 5

Install HITCH PIN R CLIP through the hole on the HITCH PIN (Fig. 1).

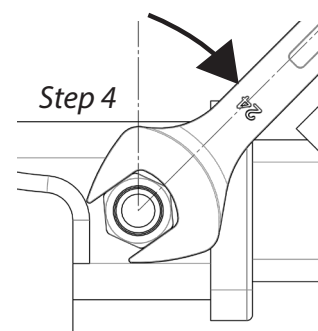

Fig 4. Tightening of Silent Anti-Rattle Hitch Pin Nut