

# TRAILBOSS

Towbar Fitting Instructions  
 To Suit SSANGYONG DUAL CAB 06/04-09/07  
 Part Number QTSY300  
 Max. Tow Rating 2500Kg  
 Max. Ball Weight 225Kg

1. Ensure all hardware items have been included
2. Remove spare wheel.
3. Using template provided mark out and drill two 12.5mm Holes on chassis rail cross member
4. On some models it may be necessary to bend rear most exhaust pipe hanger upwards to gain sufficient clearance to towbar
5. Position towbar using the two M12 bolts, nuts and spring washers and tighten to torque listing below
6. Using side arms as a guide, drill four 10.5mm holes
7. Position Bolt on wire using rear most access hole on the inside of the chassis rails and tighten to torque listing below
8. Refit spare wheel
9. Towbar rating sticker to be conspicuously located on inside rear end of the driver's door

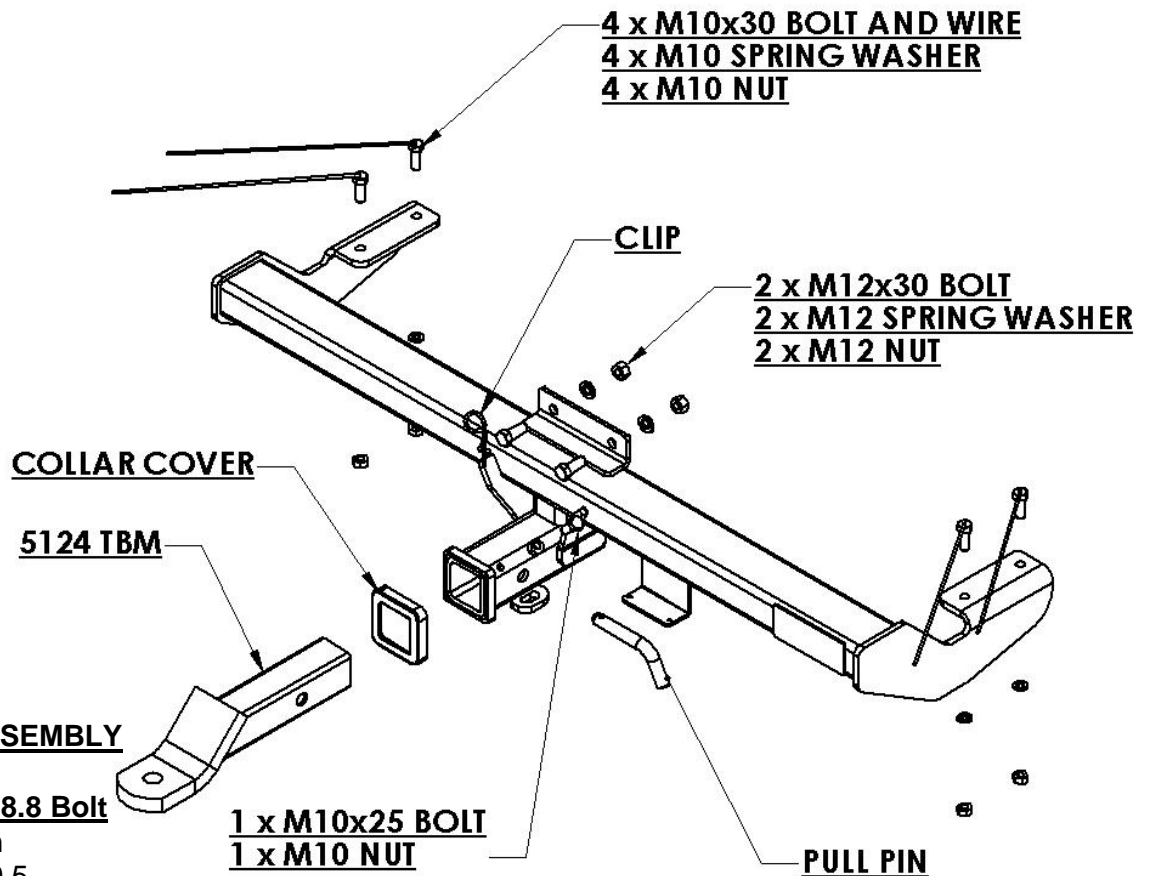

**RECOMMENDED ASSEMBLY  
 TORQUE LISTING**

<u>Diameter</u>	<u>Grade 8.8 Bolt</u> Nm
M6	9.5
M8	21.7
M10	43.4
M12	77.3
M14	121.0
M16	189.8