

TRAILBOSS

Towbar Fitting Instructions
To Suit **SSANGYONG STAVIC 2014-ON**
Part Number **QTSY304L**
Rating **2000/200** kg

PLACE THESE INSTRUCTIONS IN THE VEHICLE'S GLOVEBOX AFTER INSTALLATION IS COMPLETED

WARNING:

1. Do not, drill, cut, weld or otherwise modify the tow bar.
2. If you are using electric welding on a motor vehicle, **always** check that the vehicle is not equipped with electronic engine or instrument management equipment. Failure to do so could **destroy** any onboard computers. If in doubt, check with the vehicle's manufacturer.
3. The high tensile fasteners supplied with this product were used to achieve the specified rating. If replacement is required ensure that fasteners of the same rating & quality are used. Contact an authorised **Trailboss** dealer if further information is required.
4. If TBM is used in inverted position tow ball may make contact with rear tailgate when lowered, which could cause damage.

General:

1. Ensure all hardware items have been included refer to assembly diagram.
2. It is recommended that the instructions are read through and completely understood before making any attempt to fit this product.
3. Be wary of any changes to vehicle designs or other accessories that may conflict with the installation of this product.
4. Before drilling ensure that the area is clear of fuel, electrical & other components.
5. All holes drilled into the body panels shall have all burrs & swarf removed then coated with a suitable rust preventative paint.
6. For vehicles that require the bumper to be cut. Ensure cut out area is in correct position on the vehicle prior to cutting the bumper.
7. The high tensile fasteners supplied with this product were used to achieve the specified rating. If replacement is required ensure that fasteners of the same rating & quality are used. Contact an authorized **Trailboss** dealer if further information is required.
8. Ensure that all hardware is fastened to torque list below check fasteners on regular basis.
9. Tow bar load rating sticker provided with this product shall be conspicuously located on inside rear end of the driver's door. **(See diagram below).**
10. Trailboss recommends that you check your tow ball to ensure that it complies with the Australian standards **AS 4177.2**.
11. **PLEASE NOTE:** It is advised to remove your lug or tbm when not actually towing so as to produce a clear view of the vehicles registration plate if obscured, and to also provide maximum available departure angle
12. Pull Pin must be fit in down position.

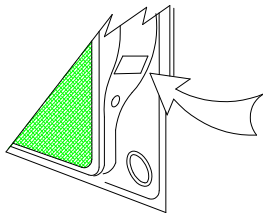

Place load rating sticker
inside driver's door here

FOR TRAILER TOWING PURPOSES ONLY
For towing capacity details please refer to vehicle owner's manual or to the manufacturer. Overloading can void your warranties.

RECOMMENDED ASSEMBLY TORQUE LISTING

Diameter	Grade 8.8 Bolt
M6	9.5 Nm
M8	21.7 Nm
M10	43.4 Nm
M12	77.3Nm
M14	146 Nm
M16	189.8 Nm

Tow bar Maintenance and Care.

Trailboss recommends that bolt torque's, as listed below, are routinely and regularly inspected and checked for correct tension. Replace any worn or defective parts.

We recommended to remove Tow Ball Mounts (TBM's, tongues or lugs) when not being used for any considerable length of time.

So as to avoid injury, when not towing it is suggested that the tongue, Pull Pin and R-clip are removed then stored in a safe, clean and dry place, away from excessive moisture.

Hitch Pull Pins and spring "R" clips are regularly checked for proper installation. Replace any worn or defective parts.

TRAILBOSS

Towbar Fitting Instructions
 To Suit **SSANGYONG STAVIC 2014-ON**
 Part Number **QTSY304L**
 Rating **2000/200 kg**

PLACE THESE INSTRUCTIONS IN THE VEHICLE'S GLOVEBOX AFTER INSTALLATION IS COMPLETED

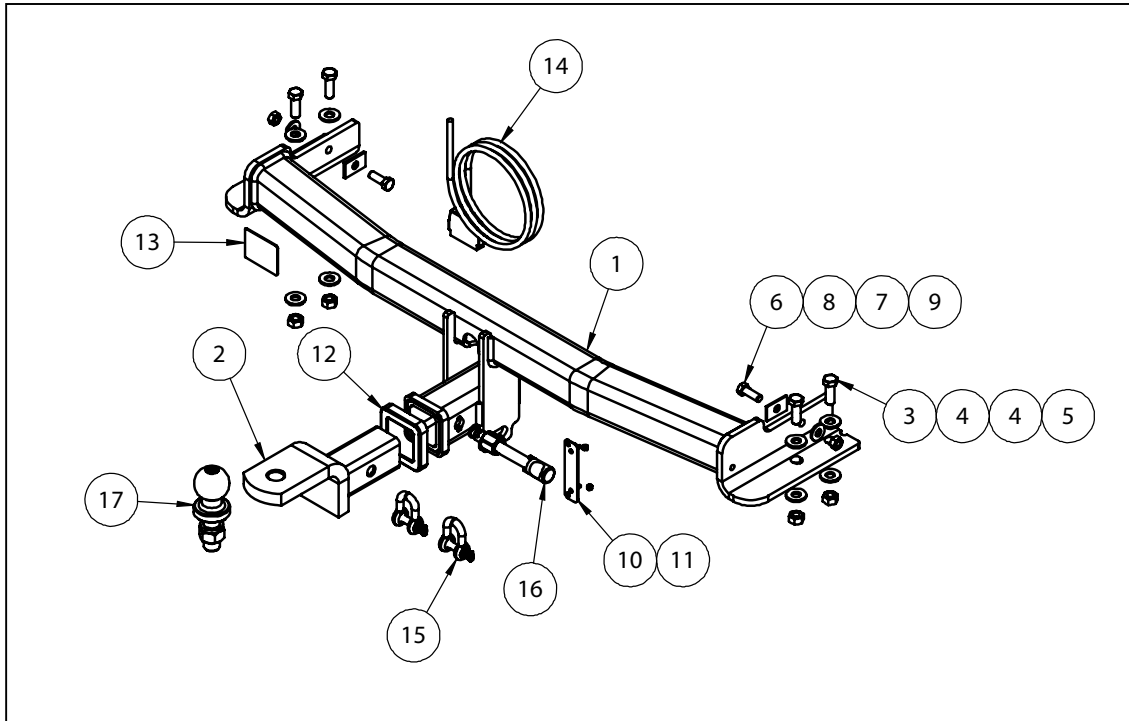

QTY	DESCRIPTION	ITEM NO
1	WELDED ASSEMBLY	1
1	TBM ASSEMBLY	2
4	SET SCREW M12-1.25x35	3
8	WASHER FLAT M12	4
4	HEX NUT M12x1.25 PC8	5
2	SET SCREW HEX HD M10x30x1.5P	6
2	WASHER FLAT M10x25.4x3	7
2	LOOSE PLATE 25x3x40	8
2	HEX NUT M10-1.5Z/P	9
1	PLUG BRACKET	10
2	NUT NYLOC M14-0.7 Z/P	11
1	HITCH BOX COLLAR COVER	12
1	ACRYLIC COMPLAINECE PLATE	13
1	WIRING LOOM	14
2	10mm "D" SHACKLE	15
1	ANTI-RATTLE PULL PIN ASSY GOLD	16
1	50mm TOWBALL	17



Towbar Fitting Instructions
To Suit **SSANGYONG STAVIC 2014-ON**
Part Number **QTSY304L**
Rating **2000/200 kg**

PLACE THESE INSTRUCTIONS IN THE VEHICLE'S GLOVEBOX AFTER INSTALLATION IS COMPLETED

INSTRUCTION:

1. From within wheel well, remove 3x screws securing rearmost mudguard to vehicle.
2. Remove 1x Screw securing rearmost mudguard, located underneath the rear bumper trim.
Place mudguard to side, repeat for opposite side of vehicle.
3. Remove 3x Scrivet securing bumper trim to rear impact beam.
4. Remove 1x Screw securing rear Bumper trim to chassis body, located inside the Bumper trim.
Screw can be accessed via the underside of vehicle, as opposed to via the wheel well.
5. Remove tail lights from vehicle by loosening 2x Screws securing lights to chassis.
6. In newly exposed cavity, remove 1x screw, repeat for opposite side of vehicle.
7. Carefully remove rear bumper trim from vehicle.
Seek assistance as trim can be difficult to remove.
8. Remove impact beam from vehicle chassis by removing 2x screws located below rear hatch seal and 2x bolts located at each chassis rail below vehicle.
Discard impact beam after removal.
9. Drill holes using template provided as a guide, locations may vary due to vehicle variation.
Align mount holes with holes in chassis rails, drilled hole will be on inside faces of chassis rails.
10. Offer Towbar to vehicle, aligning holes in Towbar with those of the chassis rail mount holes.
Secure Towbar to vehicle to recommended torques listed on page 1.
11. Cut Bumper to allow for Towbar hitchbox to fit through. Make a cut 95mm wide and 190mm long starting from the bottom lip of the trim in the centre of bumper.
Reassemble Bumper following steps 1 to 7 in reverse.



Towbar Fitting Instructions
To Suit **SSANGYONG STAVIC 2014-ON**
Part Number **QTSY304L**
Rating **2000/200 kg**

PLACE THESE INSTRUCTIONS IN THE VEHICLE'S GLOVEBOX AFTER INSTALLATION IS COMPLETED

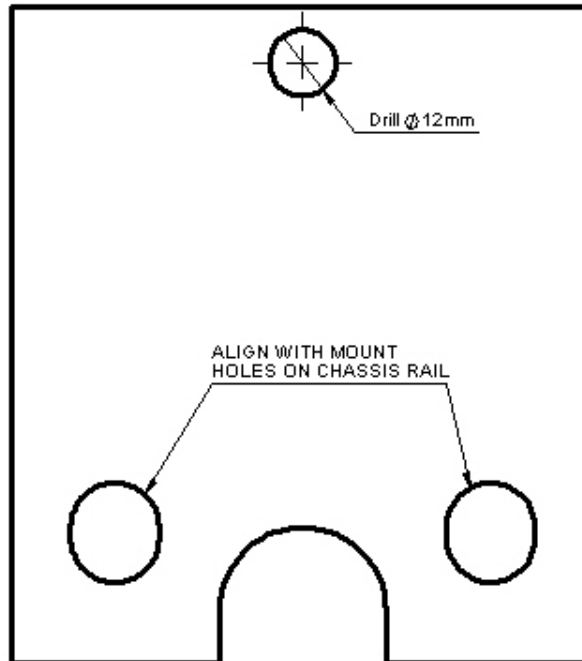
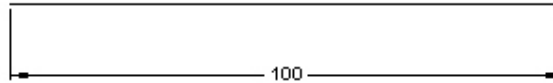



Wiring Loom Fitting Instructions
To Suit SsangYong Stavic
Part Number 101252-WL

Wiring Loom Installation Instructions

SsangYong Stavic
Part No: 101252-WL

ECU Required: 04826
Tail Harness Length Required: 1200mm

Wiring Loom Installation Time: Approx 45 Mins

TRAILBOSS

Wiring Loom Fitting Instructions To Suit SsangYong Stavic Part Number 101252-WL



Due to possible vehicle variations, always confirm any noted vehicle colour wires with a multi-meter to ensure the correct function is identified before soldering or scotch locking.

1. In the luggage compartment, fold down the rear passenger seats and remove the floor cover.
2. Remove the luggage compartment rear trim.
3. Gain access to the LHS luggage compartment access trim, by removing the LHS trim hook clips (fastener caps and screws for the RHS), and the screw at the bottom edge of the trim.
4. Dislodge enough of the luggage compartment trim to be able to reach the tail light connectors. Repeat for the RHS.
5. From inside the vehicle, pull in the LHS tail light harness grommet. Repeat for the RHS.
6. In the luggage compartment, route the trailer patch (P/No: 101252-WL) up the LHS of the vehicle tail light area.
7. From the outside of the vehicle, retrieve the trailer patch harness branch with the grommet through the tail light cavity, to the exterior of the vehicle ensuring the trailer patch grommet is seated into the previous vehicle harness grommet position. Connect the removed vehicle harness female connector to patch harness mating connector.
8. Using a tek screw, secure the trailer patch ground ring terminal to a suitable location on the vehicle sheet metal area.
9. Connect the trailer patch ECU connector to the ECU (P/No: 04826).
10. Remove the adhesive backing from the ECU and secure the ECU onto a suitable area at the LHS rear quarter of the vehicle sheet metal area. Ensure the ECU is secured with the connector pointing downwards.
11. Route the trailer patch to the RHS of the vehicle and repeat Step 7 for the RHS tail light connections.
12. Locate and un-tape the vehicle harness above the wheel arch area and locate the reverse signal wire.
13. Following the table below, connect the ezy-tap to the corresponding vehicle wire and then connect the trailer patch terminal to the ezy-tap.

Function	Trailer Patch	Vehicle Connector
REVERSE	BLACK/WHITE	LIGHT GREEN

Important! Always test vehicle wires first with the multi-meter as wire colours may vary depending on vehicle variant.

14. At the LHS rear of the vehicle, route the tail harness (tail length: 1200mm) into the vehicle grommet. Adjust the tail harness grommet ensuring it is seated correctly.
15. Pierce a hole into the now seated tail harness grommet and route the power harness 1-way connector into the vehicle. Connect the power harness 1-way connector to the trailer patch 1-way connector.
16. Route the power harness underneath the vehicle along the vehicle chassis rail and up



Wiring Loom Fitting Instructions
To Suit SsangYong Stavic
Part Number 101252-WL

towards the engine bay battery.

17. Secure the power harness ring terminal to the vehicle positive battery using the battery fastener.
18. At the rear of the vehicle, secure the trailer socket to the towbar mounting bracket using M4 fasteners (not supplied). Secure the tail harness grommet into place using a cable tie (not supplied).
19. Inside the vehicle, connect the tail harness (tail length: 1200mm) 8-way connector to the Trailer Patch 8-way mating connector
20. Refit the LHS and RHS tail light assemblies.
21. Test the trailer harness functions using a multi-meter.
22. Secure all harnesses using cable ties (not supplied).
23. Re-fit removed parts and secure all fasteners, ensuring there are no squeaks or rattles.
24. Place the instructions in the glove box after fitment.



FITTING INSTRUCTIONS

Silent Anti-Rattle Hitch Pin (PR0001)

• These fitting instructions are supplied to ensure understanding of how the HITCH PIN should be fitted and used correctly.

• Once installed, we recommend **ALL** instructions are kept and placed in the vehicle glove box.

NOTE: Routine maintenance and inspection of the towbar & HITCH PIN is required. Regularly inspect for wear and check the tightness of the Hitch Pin. Follow instructions below to retighten the nut when necessary.

***Do not tow with your vehicle if the R CLIP or the HITCH PIN is loose or missing. Replacement parts are available from your Pro Series Distributor.**

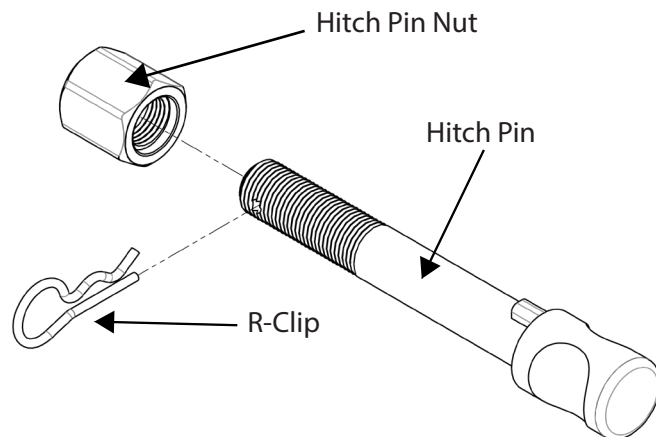

Fig 1. Silent Anti-Rattle Hitch Pin assembly

STEP 1

Insert Trailer Ball Mount (TBM) into towbar HITCHBOX, aligning hole in TBM SHANK with hole in HITCHBOX (Fig 2).

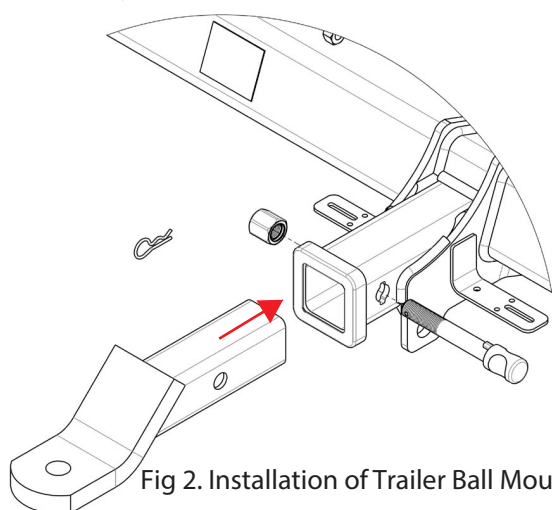

Fig 2. Installation of Trailer Ball Mount

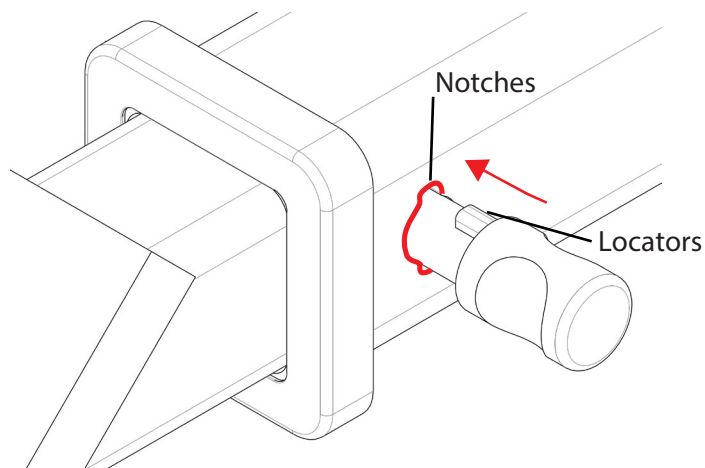

Fig 3. Silent Anti-Rattle Hitch Pin orientation

STEP 2

Insert HITCH PIN through hole in HITCHBOX and hole in TBM SHANK; ensure the LOCATORS are inserted into the NOTCHES in the HITCHBOX (Fig. 3).

STEP 3

Screw HITCH PIN NUT onto HITCH PIN; tighten HITCH PIN NUT until finger tight, ensuring TBM is restrained from movement.

STEP 4

Tighten HITCH PIN NUT by turning nut a further 1/8th of a turn in the clockwise direction using a 24mm spanner (Fig. 4).

STEP 5

Install HITCH PIN R CLIP through the hole on the HITCH PIN (Fig. 1).

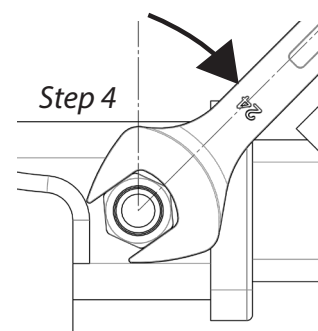

Fig 4. Tightening of Silent Anti-Rattle Hitch Pin Nut