

TRAILBOSS

Towbar Fitting Instructions
To Suit **ZX AUTO GRAND TIGER DIESEL W/OUT STEP 2013 ON**
Part Number **QTZA002L**
Rating **2000/180 kg**

PLACE THESE INSTRUCTIONS IN THE VEHICLE'S GLOVEBOX AFTER INSTALLATION IS COMPLETED

WARNING:

1. Do not, drill, cut, weld or otherwise modify the tow bar.
2. If you are using electric welding on a motor vehicle, **always** check that the vehicle is not equipped with electronic engine or instrument management equipment. Failure to do so could **destroy** any onboard computers. If in doubt, check with the vehicle's manufacturer.
3. The high tensile fasteners supplied with this product were used to achieve the specified rating. If replacement is required ensure that fasteners of the same rating & quality are used. Contact an authorised **Trailboss** dealer if further information is required.
4. If TBM is used in inverted position tow ball may make contact with rear tailgate when lowered, which could cause damage.

General:

1. Ensure all hardware items have been included refer to assembly diagram.
2. It is recommended that the instructions are read through and completely understood before making any attempt to fit this product.
3. Be wary of any changes to vehicle designs or other accessories that may conflict with the installation of this product.
4. Before drilling ensure that the area is clear of fuel, electrical & other components.
5. All holes drilled into the body panels shall have all burrs & swarf removed then coated with a suitable rust preventative paint.
6. For vehicles that require the bumper to be cut. Ensure cut out area is in correct position on the vehicle prior to cutting the bumper.
7. The high tensile fasteners supplied with this product were used to achieve the specified rating. If replacement is required ensure that fasteners of the same rating & quality are used. Contact an authorized **Trailboss** dealer if further information is required.
8. Ensure that all hardware is fastened to torque list below check fasteners on regular basis.
9. Tow bar load rating sticker provided with this product shall be conspicuously located on inside rear end of the driver's door. **(See diagram below).**
10. Trailboss recommends that you check your tow ball to ensure that it complies with the Australian standards **AS 4177.2.**
11. **PLEASE NOTE:** It is advised to remove your lug or tbn when not actually towing so as to produce a clear view of the vehicles registration plate if obscured, and to also provide maximum available departure angle
12. Pull Pin must be fit in down position.

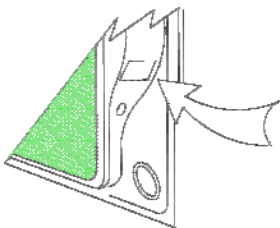

Place load rating sticker
inside driver's door here

FOR TRAILER TOWING PURPOSES ONLY
For towing capacity details please refer to vehicle owner's
manual or to the manufacturer. Overloading can void your
warranties.

Tow bar Maintenance and Care.

Trailboss recommends that bolt torque's, as listed below, are routinely and regularly inspected and checked for correct tension. Replace any worn or defective parts.

We recommended to remove Tow Ball Mounts (TBM's, tongues or lugs) when not being used for any considerable length of time.

So as to avoid injury, when not towing it is suggested that the tongue, Pull Pin and R-clip are removed then stored in a safe, clean and dry place, away from excessive moisture.

Hitch Pull Pins and spring "R" clips are regularly checked for proper installation. Replace any worn or defective parts.

TRAILBOSS

Towbar Fitting Instructions

To Suit **ZX AUTO GRAND TIGER DIESEL W/OUT STEP 2013 ON**

Part Number **QTZA002L**

Rating **2000/180 kg**

PLACE THESE INSTRUCTIONS IN THE VEHICLE'S GLOVEBOX AFTER INSTALLATION IS COMPLETED

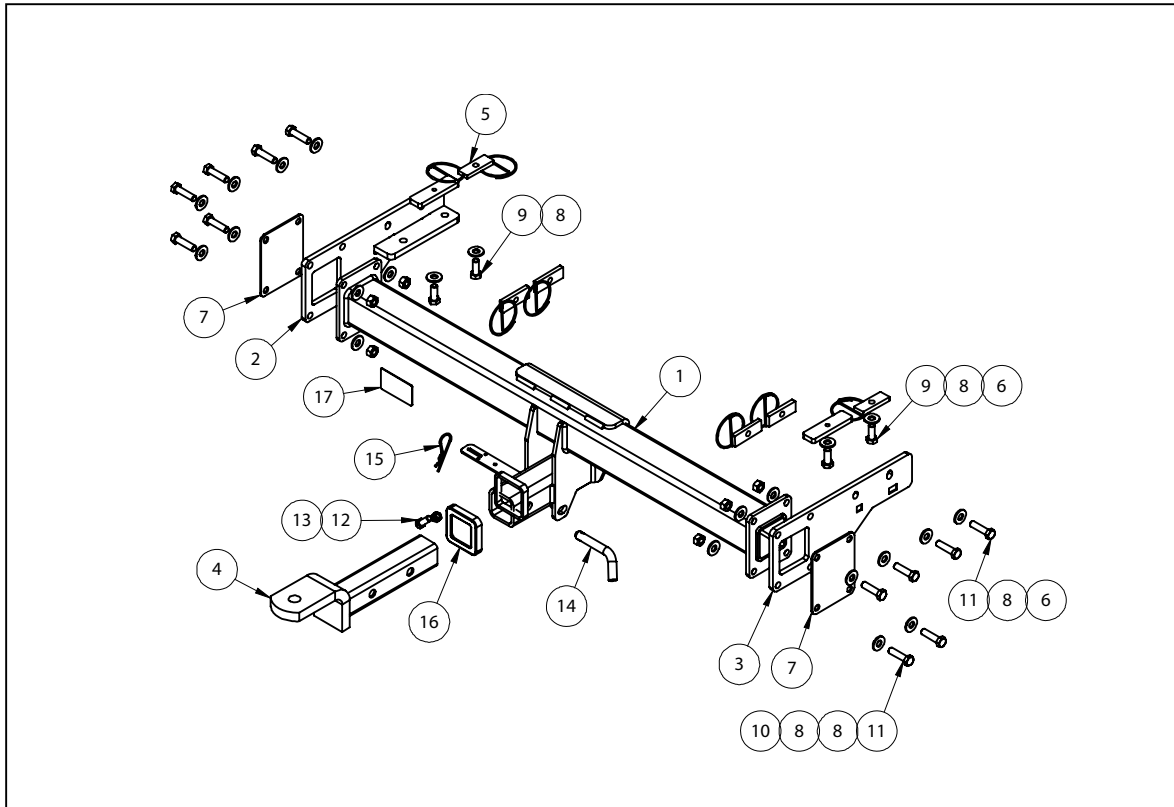

QTY	DESCRIPTION	ITEM NO
1	ZX AUTO GRAND TIGER TOWBAR ASSY	1
1	LHS END PLATE ASSEMBLY	2
1	RHS END PLATE ASSY	3
1	CLASS 4 TBM	4
2	M12 FITTING PLATE WITH 300mm WIRE	5
6	FITTING PLATE TAPED M12x1.25P	6
2	END COVER PLATE 4x2 TRAY	7
24	WASHER FLAT M12	8
4	M12x30x1.25P BOLT	9
8	M12x1.25P HEX NUT	10
12	SET SCREW M12x45x1.25P	11
1	SET SCREW M10x30x1.5P	12
1	HEX NUT M10x1.5P	13
1	PULL PIN	14
1	R CLIP	15
1	HITCH BOX COLLAR COVER	16
1	ACRYLIC CP LABEL	17

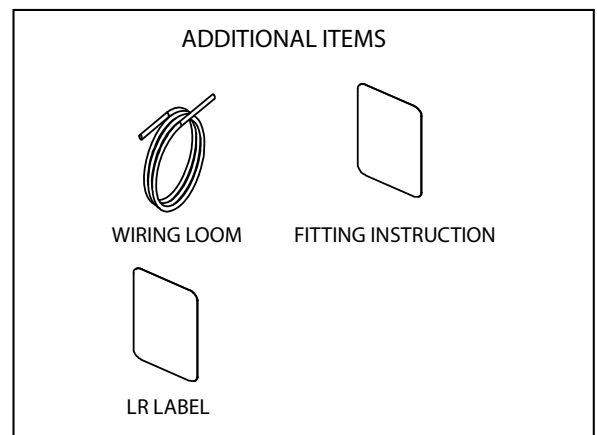



Towbar Fitting Instructions
To Suit **ZX AUTO GRAND TIGER DIESEL W/OUT STEP 2013 ON**
Part Number **QTZA002L**
Rating **2000/180 kg**

PLACE THESE INSTRUCTIONS IN THE VEHICLE'S GLOVEBOX AFTER INSTALLATION IS COMPLETED

INSTRUCTION:

1. Drill out the most forward into the vehicle Pilot Hole, LHS and RHS, located underneath the Chassis Rail using a 13mm drill bit.
2. Loosely secure the Towbar Sidearms to the outside of the Chassis Rail using 2x M12 Bolts, Washers and Taped Plates on both sides of the vehicle.
3. Loosely secure the vertical mounting points of the Sidearms using 2x M12 Bolts, Washers, one M12 long Taped Plate for the most rearward mounting point and an M12 Taped Plate for the most forward mounting point.
4. Offer the main Towbar assembly to the vehicle and slot into the sidearms.
5. Align the Cover Plates to the outside of the sidearms. Secure the Cover plates to the sidearms and Towbar Centre with 4x M12 Bolts, Washers and Nuts.
6. Torque all bolts to the following:
 - 8 x M12 Bolts through side arms and towbar centre section to 93Nm.
 - 4 x M12 Bolts through sidearms and chassis rail to 93Nm (vertical).
 - 4 x M12 Bolts through sidearms and chassis rail to 93Nm (horizontal).
7. Please note the following:
 - 4x2 Cab Chassis , trailer ball mount is to be mounted in the UP position.
 - 4x4 Cab Chassis, trailer ball mount is to be mounted in the DOWN position.
 - For Cab Chassis, use the most forward pull pin hole to secure the tow ball mount to the Hitchbox.



Wiring Loom Fitting Instructions
To Suit ZX Auto Grand Tiger MY12
Part Number 100772-WL

Wiring Loom Installation Instructions

ZX Auto Grand Tiger MY12
Part No: 100772-WL

Tail Harness Length Required: 1200mm

Wiring Loom Installation Time: Approx 20 Mins



Wiring Loom Fitting Instructions
To Suit ZX Auto Grand Tiger MY12
Part Number 100772-WL

1. On the rear of the vehicle, locate the LHS 6-way tail light connector.
2. Disconnect the 6-way tail light connectors and connect the trailer harness (100772-WL) connector in between.
3. Route the trailer harness along the rear chassis towards the RHS of the vehicle.
4. On the RHS of the vehicle, disconnect the 6-way tail light connectors and connect the trailer harness connectors in between.
5. Mount the trailer socket to the tow bar mounting bracket using M4 fasteners (not supplied).
6. Route the tail harness across the tow bar towards its 8-way mating connector.
7. Connect the tail harness (tail length 1200mm) 8-way connector to the trailer patch mating 8-way connector.
8. Test the trailer patch function using a light board or multi meter.
9. Secure all harnesses using cable ties (not supplied).
10. Re-fit all removed parts and secure all fasteners, ensuring there are no squeaks or rattles.
11. Place the fitting instructions in the glove box after fitment.