



Towbar Fitting Instructions  
To Suit TOYOTA COROLLA SECA HATCH 9/94-ON  
HOLDEN NOVA HATCHBACK 4 DOOR 10/94-ON  
Part Number TT115  
Rating 850Kg

1. Ensure all hardware items have been included.
2. Remove and discard shipping hook from passenger side.
3. Remove two bolts securing exhaust hanger from drivers side.
4. Remove two bolts securing bumper to spare wheel well.
5. Cut bumper bar as per diagram.
6. Lift towbar into position by pulling down bumper bar edge and manoeuvring towbar between bumper and body.
7. Align towbar holes with shipping hook bolt holes and fit bolts and loose plates supplied. (Refer to diagram for loose plate positioning.)
8. Tighten all bolts to torque listing below.
9. Remove spare wheel.
10. Using remaining hole in towbar as a guide, drill an 11mm hole into spare wheel well.
11. Fit bolt and loose plate supplied and tighten to torque listing below.

**RECOMMENDED ASSEMBLY TORQUE LISTING**

<u>Diameter</u>	<u>Grade 8.8 Bolt</u>
	<u>Nm</u>
M6	9.5
M8	21.7
M10	43.4
M12	77.3
M14	121.0
M16	189.8

Towbar Fitting Instructions  
To Suit TOYOTA COROLLA SECA HATCH 9/94-ON  
HOLDEN NOVA HATCHBACK 4 DOOR 10/94-ON  
Part Number TT115  
Rating 850Kg

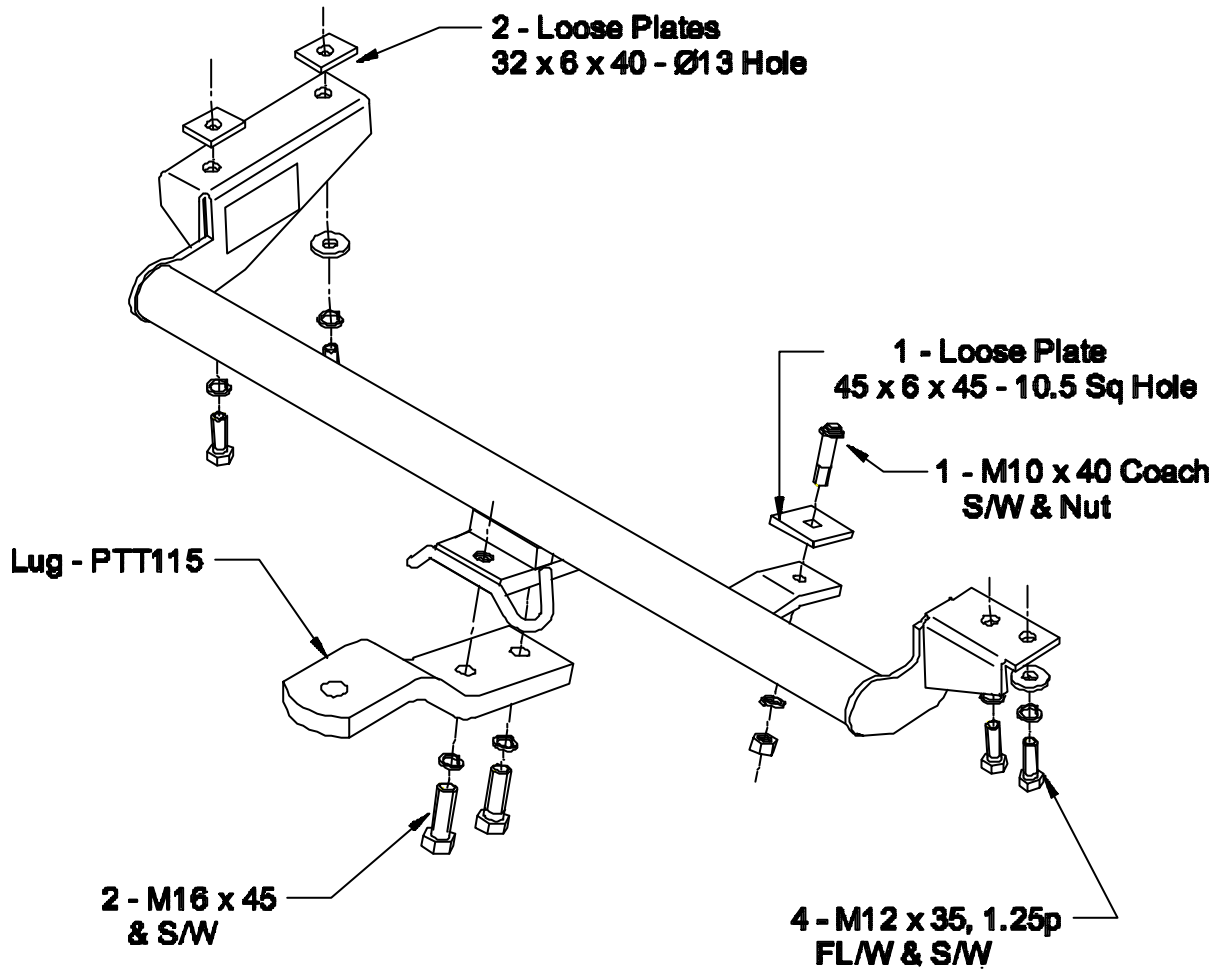

Towbar Fitting Instructions  
To Suit TOYOTA COROLLA SECA HATCH 9/94-ON  
HOLDEN NOVA HATCHBACK 4 DOOR 10/94-ON  
Part Number TT115  
Rating 850Kg

