

# TRAILBOSS

Towbar Fitting Instructions  
To Suit **TOYOTA YARIS** 2011 ON  
Part Number **TT156L**  
Rating **900/90** kg

PLACE THESE INSTRUCTIONS IN THE VEHICLE'S GLOVEBOX AFTER INSTALLATION IS COMPLETED

## **WARNING:**

1. Do not, drill, cut, weld or otherwise modify the tow bar.
2. If you are using electric welding on a motor vehicle, **always** check that the vehicle is not equipped with electronic engine or instrument management equipment. Failure to do so could **destroy** any onboard computers. If in doubt, check with the vehicle's manufacturer.
3. The high tensile fasteners supplied with this product were used to achieve the specified rating. If replacement is required ensure that fasteners of the same rating & quality are used. Contact an authorised **Trailboss** dealer if further information is required.

## **General:**

1. Ensure all hardware items have been included refer to assembly diagram.
2. It is recommended that the instructions are read through and completely understood before making any attempt to fit this product.
3. Be wary of any changes to vehicle designs or other accessories that may conflict with the installation of this product.
4. Before drilling ensure that the area is clear of fuel, electrical & other components.
5. All holes drilled into the body panels shall have all burrs & swarf removed then coated with a suitable rust preventative paint.
6. For vehicles that require the bumper to be cut. Ensure cut out area is in correct position on the vehicle prior to cutting the bumper.
7. The high tensile fasteners supplied with this product were used to achieve the specified rating. If replacement is required ensure that fasteners of the same rating & quality are used. Contact an authorized **Trailboss** dealer if further information is required.
8. Ensure that all hardware is fastened to torque list below check fasteners on regular basis.
9. Tow bar load rating sticker provided with this product shall be conspicuously located on inside rear end of the driver's door. **(See diagram below)**.
10. Trailboss recommends that you check your tow ball to ensure that it complies with the Australian standards **AS 4177.2**.
11. **PLEASE NOTE:** It is advised to remove your lug or tbm when not actually towing so as to produce a clear view of the vehicles registration plate if obscured, and to also provide maximum available departure angle
12. Pull Pin must be fit in down position.

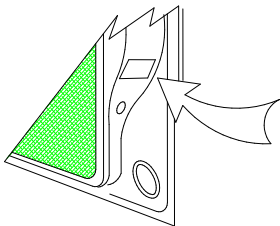

Place load rating sticker  
inside driver's door here

**FOR TRAILER TOWING PURPOSES ONLY**  
For towing capacity details please refer to vehicle owner's manual or to the manufacturer. Overloading can void your warranties.

### RECOMMENDED ASSEMBLY TORQUE LISTING

Diameter	Grade 8.8 Bolt
M6	9.5 Nm
M8	21.7 Nm
M10	43.4 Nm
M12	77.3Nm
M14	146 Nm
M16	189.8 Nm

## **Tow bar Maintenance and Care.**

Trailboss recommends that bolt torque's, as listed below, are routinely and regularly inspected and checked for correct tension. Replace any worn or defective parts.

We recommended to remove Tow Ball Mounts (TBM's, tongues or lugs) when not being used for any considerable length of time.

So as to avoid injury, when not towing it is suggested that the tongue, Pull Pin and R-clip are removed then stored in a safe, clean and dry place, away from excessive moisture.

Hitch Pull Pins and spring "R" clips are regularly checked for proper installation. Replace any worn or defective parts.

# TRAILBOSS

Towbar Fitting Instructions  
 To Suit **TOYOTA YARIS** 2011 ON  
 Part Number **TT156L**  
 Rating **900/90** kg

PLACE THESE INSTRUCTIONS IN THE VEHICLE'S GLOVEBOX AFTER INSTALLATION IS COMPLETED

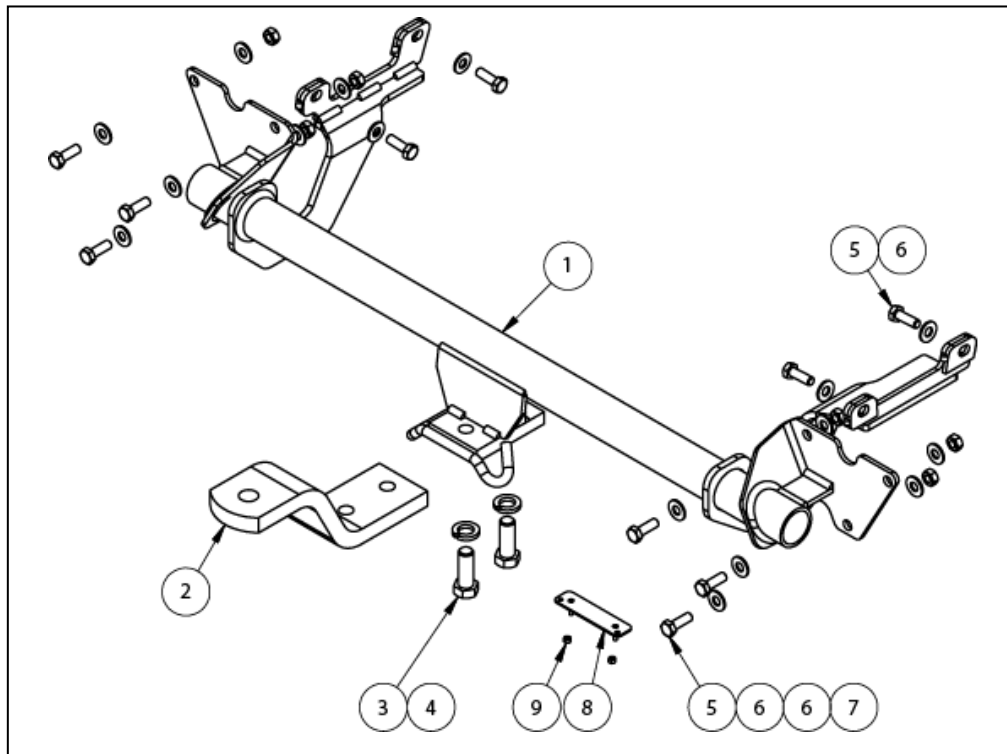

QTY.	DESCRIPTION	ITEM NO.
1	WELDED ASSEMBLY	1
1	ASSEMBLY LUG	2
2	M16x45 2.0P BOLT	3
2	M16x5x3.5 SPRING WASHER	4
10	BOLT M10-1.25x30 GR 8.8 Z/P	5
16	WASHER FLAT M10x23x2 Z/P	6
6	NUT HX M10-1.25 Z/P	7
1	PLUG BRACKET	8
2	NUT NYLOC M4-0.7 Z/P	9

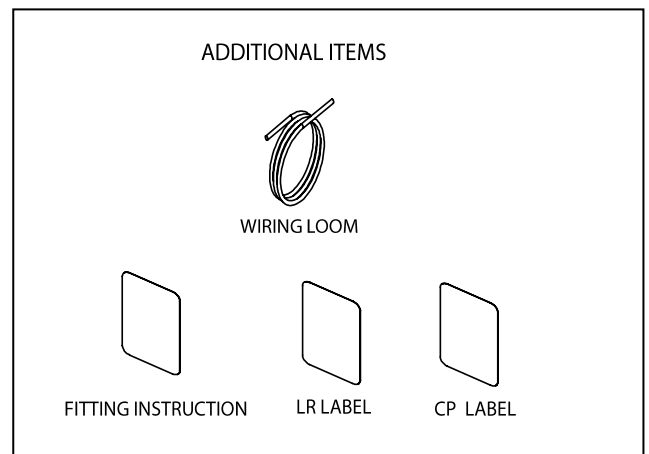



Towbar Fitting Instructions  
To Suit **TOYOTA YARIS** 2011 ON  
Part Number **TT156L**  
Rating **900/90** kg

PLACE THESE INSTRUCTIONS IN THE VEHICLE'S GLOVEBOX AFTER INSTALLATION IS COMPLETED

**INSTRUCTION:**

1. Remove 3 Scrivets from under side of Bumper Bar for both LH & RH side.
2. Open boot and remove 2 Screws from Bumper and then firmly pull on Bumper to detach from Plastic Clips holding it in place.
3. Remove 3 Bolts from both LH & RH side of Impact Beam and discard Bolts and Impact Beam.
4. Drop exhaust from both front and rear Rubber Mounts.
5. Drill out and completely remove 3 captive Nuts for both LH & RH side using a 12mm drill bit.  
Offer up Towbar to vehicle and loosely Bolt the 3 M10 Bolts, Washers and Nuts for both the LH & RH side.
6. Using 2 M10 Bolts and Washers bolt the side Chassis Rail Brackets to the existing M10 captive Nuts for both the LH & RH side.
7. Tighten all bolts to torque specifications provided
8. Cut Bumper 25mm long and 120mm wide and proceed to reinstall bumper in reverse order to disassembly.



Wiring Loom Fitting Instructions  
To Suit Toyota Yaris MY12  
Part Number 100840-WL

Wiring Loom Installation Instructions

Toyota Yaris MY12  
Part No: 100840-WL

Tail Harness Length Required: 1200mm  
ECU Required: 04826

Wiring Loom Installation Time: Approx 45 Mins

## Wiring Loom Fitting Instructions To Suit Toyota Yaris MY12 Part Number 100840-WL

1. In the luggage compartment, remove the carpet covers and the sunshade.
2. Remove the rear luggage compartment trim by pulling in an upwards direction.
3. On the LHS of the luggage compartment, dislodge the luggage compartment trim by first removing the three bolts.
4. On the RHS of the luggage compartment, remove the luggage compartment access panel trim.
5. On the LHS front passenger side, remove the door sill trim.
6. Inside the luggage compartment, drill a Ø30mm hole (1) on the LHS of the wheel well.

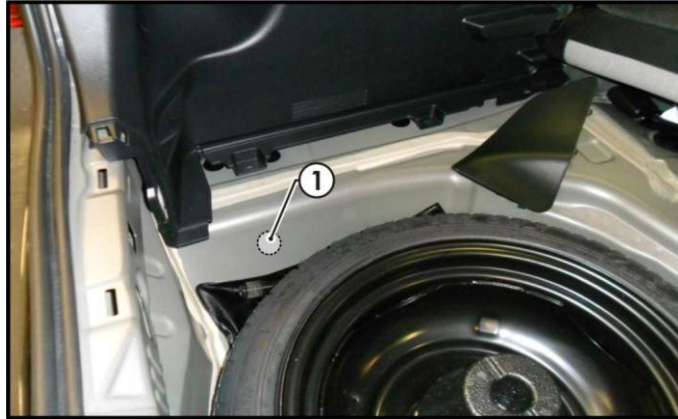

7. File any rough or sharp edges and spray with rust inhibitor.
8. On the RHS of the luggage compartment, disconnect the tail light connector and connect the trailer harness (100840-WL) connectors in between.
9. Route the trailer harness along the rear luggage compartment towards the LHS tail light connectors.
10. On the LHS of the luggage compartment, disconnect the tail light connector and connect the trailer harness connectors in between.
11. On the LHS of the luggage compartment, connect the trailer patch ground ring terminal to the vehicle grounding point.
12. Apply double sided tape to the ECU and adhere it to the vehicle sheet metal on the LHS of the luggage compartment in a suitable location.
13. Connect the trailer patch 12-way connector to the ECU.

## Wiring Loom Fitting Instructions To Suit Toyota Yaris MY12 Part Number 100840-WL

14. Route the 'ORANGE' power wire along the LHS of the luggage compartment trim underneath the carpet, towards the front of the vehicle.
15. Following the existing vehicle harness, route the 'ORANGE' power wire along the LHS of the vehicle towards the fuse panel.
16. Inside the fuse panel, locate the 15-amp fuse (1) as shown and discard.
17. Insert the two supplied 15 Amp mini fuses (2) into the slots of the add-a-fuse (3).
18. Plug the add-a-fuse (3) into the previously removed 15-amp fuse slot on the fuse panel.
19. Connect the power patch 1-way connector (4) into the add-a-fuse harness mating connector (5).

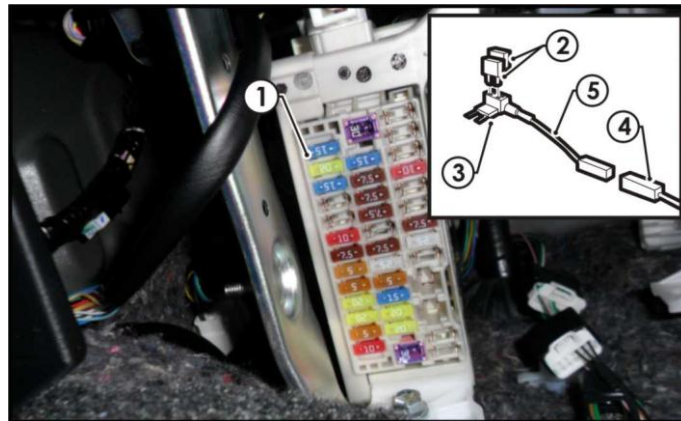

20. Mount the trailer socket to the tow bar mounting bracket using M4 fasteners (not supplied).
21. Route the tail harness across the tow bar towards the LHS of the vehicle and up through the previously drilled out hole.
22. Ensure the tail harness grommet is seated correctly and secure in place using a cable tie (not supplied).
23. Connect the tail harness (tail length 1200mm) 8-way connector to the trailer patch mating 8-way connector.
24. Test the trailer patch function using a light board or multi meter.
25. Secure all harnesses using cable ties (not supplied).
26. Re-fit all removed parts and secure all fasteners, ensuring there are no squeaks or rattles.
27. Place the fitting instructions in the glove box after fitment.